



**POLEA TENSORA COMPACT 200**

**COMPACT 200 TENSING PULLEY**

**POULIE DE TENSION COMPACT 200**

**SPANROLLE COMPACT 200**

**INSTRUCCIONES DE USO Y MANUTENCIÓN/  
INSTRUCTIONS FOR USE AND MAINTENANCE/  
INSTRUCTIONS D'USAGE ET ENTRETIEN/  
GEBRAUCHS- UND WARTUNGSANLEITUNG/**

## TYPE EXAMINATION CERTIFICATE

Certificate number.	MD_EVN_130055
Certification agency.	<b>Asistencia Técnica Industrial S.A.E. (ATISAE)</b> Avda. de la Industria, 51 bis E 28760 Tres Cantos MADRID (ESPAÑA)
Class. Type.	<b>Tensioning system with springs for conventional overspeed governor</b>
Model	<b>COMPACT 200</b>
Manufacturer.	<b>DYNATECH. DYNAMICS AND TECHNOLOGY, S.L</b> <b>POL. IND. PINA DE EBRO, SECTOR C, PARC 9</b> <b>50750 PINA DE EBRO – ZARAGOZA</b>
Certificate holder.	<b>DYNATECH. DYNAMICS AND TECHNOLOGY, S.L</b> <b>POL. IND. PINA DE EBRO, SECTOR C, PARC 9</b> <b>50750 PINA DE EBRO – ZARAGOZA</b>
Type examination date.	<b>06.06.2013</b>
Standard of reference. <sup>(1)</sup>	<b>EN 81-1:1998 + A3:2009</b>
ATISAE's report.	<b>MD_EVN_130055</b>

**statement:** The assessed component "tensioning system with springs", may be used in connection with an overspeed governor within the scope given in clause 9.9 of EN 81-1:1998.

ATISAE is a Notified Body (0053) for the European Lifts Directive 95/16/EC. However, since the subject of this certificate, this issuing does not fall within any of the assessment procedures of the aforementioned Directive, but in the context of voluntary assessment of a product, which can be part of a safety component, that is carried out by an independent or third party.

For legal reasons, provided that this is not a safety component, this agency cannot issue an EC type examination certificate.

This certificate may be used as a justification of the allowable scope of the system, being part in the scope of an overspeed governor. Because of the nature of the scope, it is necessary the assessment of the governor and its tensioning pulley on the tensile force tests



(1) The scope is set on the technical annex.

Simón Viñas Sáez  
Inspector

José Manuel Flórez González  
Director Técnico de Elevación

This certificate consists of this cover, a technical annex of two page san one plan.  
Only complete reproduction may be taken as valid.

## INSTRUCTIONS FOR USE AND MAINTENANCE

---

<b>1</b>	<b>INTRODUCTION</b> .....	<b>2</b>
<b>2</b>	<b>INSTRUCTIONS FOR USE AND MAINTENANCE</b> .....	<b>2</b>
2.2	ASSEMBLE THE INSTALLATION.....	2
2.2.1	COMPACT GUIDE RAIL ADAPTER .....	3
2.3	ASSEMBLE THE GOVERNOR'S ROPE.....	3
2.4	ROPE TIGHTENING.....	3
2.5	DE-TENSING CONTACT .....	4
2.6	ROPE RE-TIGHTENING .....	5
<b>3</b>	<b>TIPS</b> .....	<b>5</b>
<b>4</b>	<b>ASSEMBLY'S DRAWINGS</b> .....	<b>5</b>

---

## 1 INTRODUCTION

Compact tensing pulley is a product designed to provide the governor's rope with the tension required. It is a compact and perfect design to be used in installations with reduced space.

To design the Compact tensing pulley all its dimensions were reduced to the maximum.

This tensing pulley is a Dynatech product that is supplied pre-assembled. This allows the installer to save time when assembling it in the installation.

## 2 INSTRUCTIONS FOR USE AND MAINTENANCE

The key points to be taken into account are as follows:

- i. The assembly instructions for each tensing pulley are to be observed.
- ii. Compact tensing pulley is to be used with governors of a standard nature, with a governor's rope forming a closed loop.
- iii. The groove in the governor's main pulley is to be hardened.
- iv. Its use is valid for governor's ropes with the following diameters: 6, 6.5 mm.
- v. The Compact tensing pulley is to be properly located so that the rope going past the governor's and tensing pulleys flows correctly and, therefore, avoids decreasing the lifespan of both the rope and the governor's pulley groove, thus ensuring that the tensing pulley operates correctly.
- vi. Prevent bumps or dents.
- vii. It is recommended to periodically check the wear and tear of the groove in the governor's main pulley.

### 2.2 ASSEMBLE THE INSTALLATION

First, before finally securing the Compact tensing pulley in the installation, it is essential to correctly position it so that the rope is suitably assembled and thus ensuring its correct operation in the future.

To do so, fit it in such a way that the governor's rope (12), either the branch coming from the governor or the one going to the driving bar's governor attachment (13), exactly coincides with the pulley's groove. That is to say, both branches of the governor's rope must form a 90° angle with the upper cover of the Compact tensing pulley.

Once it is ensured that the governor's rope branches perfectly coincide with the pulley's groove, fix the Compact tensing pulley to the installation's floor via two M12 screws at the anchoring points (11) arranged for this purpose. See Figure 3.

Drawing DYN 66.C001.00 displays the distances between the anchoring points.

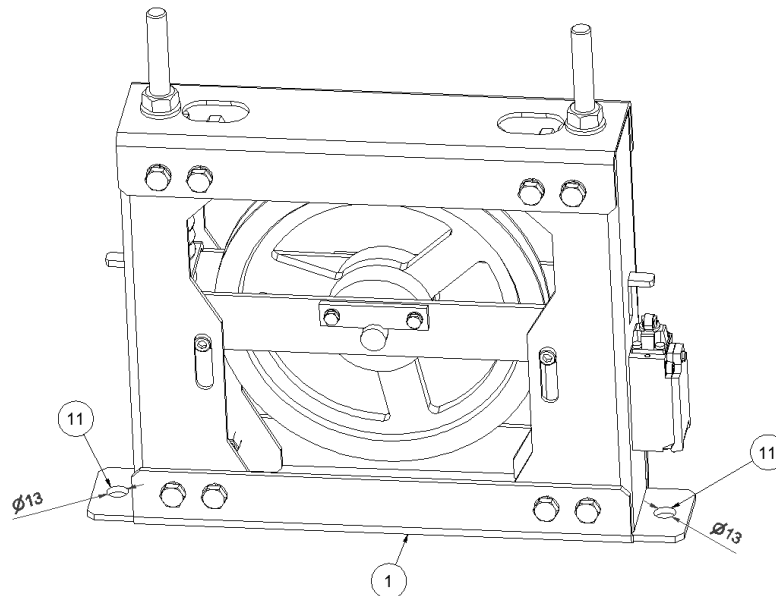

**Figure 3: Compact tensing pulley's anchoring points**

### 2.2.1 COMPACT GUIDE RAIL ADAPTER

The Compact tensing pulley may also be fixed to the guide rail by assembling an adapter.

## 2.3 ASSEMBLE THE GOVERNOR'S ROPE

Once the Compact tensing pulley has been fixed, assemble the governor's rope onto the tensing pulley.

Insert the free end of one of the rope's branches into the holes on the upper bracket (7). Pass the rope's end between the pulley's groove (2) and the release-prevention device (8), surrounding the pulley (2), continuing up to the other release-prevention device (8) and going out at the hole opposite the one it was inserted.

Then, pass the free end of the rope previously passed through the tensing pulley through the driving bar's governor attachment (13). It is important to apply some tension on the rope's end (12), when assembling the cable clip (14) fixing the rope to driving bar's governor attachment (13).

## 2.4 ROPE TIGHTENING

Before tightening the rope, please make sure that the cable-clips are correctly assembled.

To tighten the rope, unthread the spring-compressing nuts (5). To do so, it is recommended to unthread both nuts almost at the same time. That is to say, alternate the unthreading process of each nut so that both rope-tensing springs (3) become released at the same time, the pulley (2) uniformly lowers and the rope (12) becomes tightened.

As the nuts (5) are being unthreaded, the governor's rope (12) becomes tightened. Unthread the nuts (5) until the springs are completely released. It is recommended to assemble these nuts (5) at the end of the spring-compressing rods (4) as displayed in Figure 19

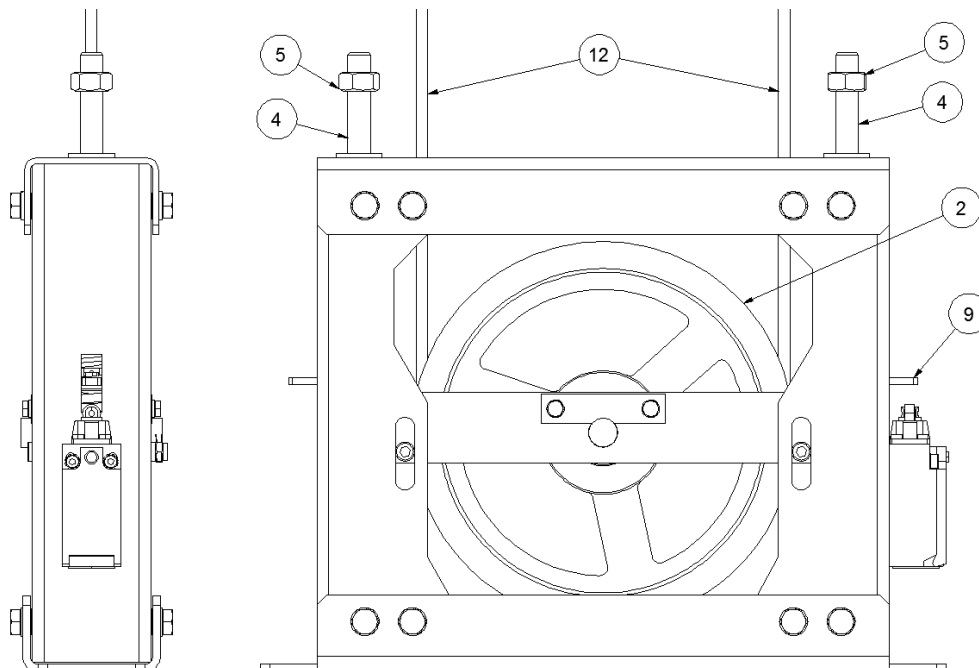

**Figure 19: Position after tightening the rope**

If, after completely unthreading the nuts, it is detected that the de-tensing contact actuator (9) is in contact or about to contact the de-tensing contact (10) (See Figure 20), release the rope (13) from the cable-clips (14), and pre-tighten the free end of the rope again .

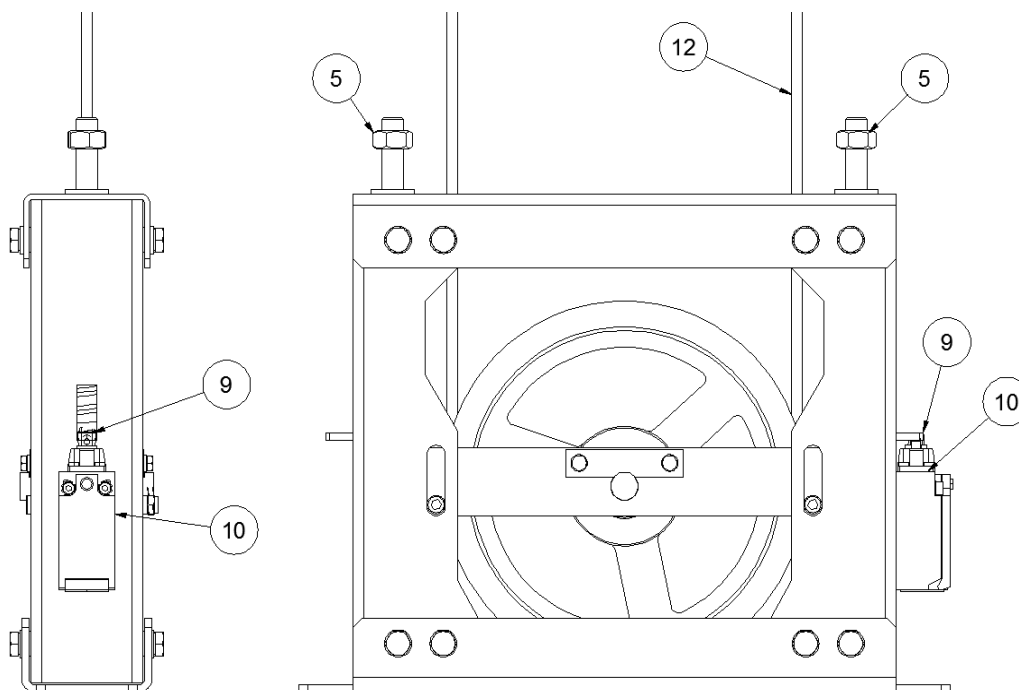

**Figure 20: Rope without the correct tension**

**Note:** For the Compact tensing pulley to operate correctly, once the rope tension is correct, the nuts (5) are to be placed at the end of the rods (4) and, thus allowing the vertically movement of the pulley (2) and the de-tensing contact actuator (9) and, as a result, the natural untightening of the rope.

## 2.5 DE-TENSING CONTACT

Due to the normal elongation of the rope, untightening may occur.

To detect rope untightening or even breakage, Compact tensing pulley incorporates an electrical contact (10). This contact (10) is to be connected to the installation's safety line.

In case of rope untightening or breakage, the contact (9) will be activated by the de-tensing contact Actuator (9), (see Figure 21), thus ensuring the drive machine stop.

**Note:** Compact tensing pulley allows assembling the contact (9) both in the right and left vertical brackets.

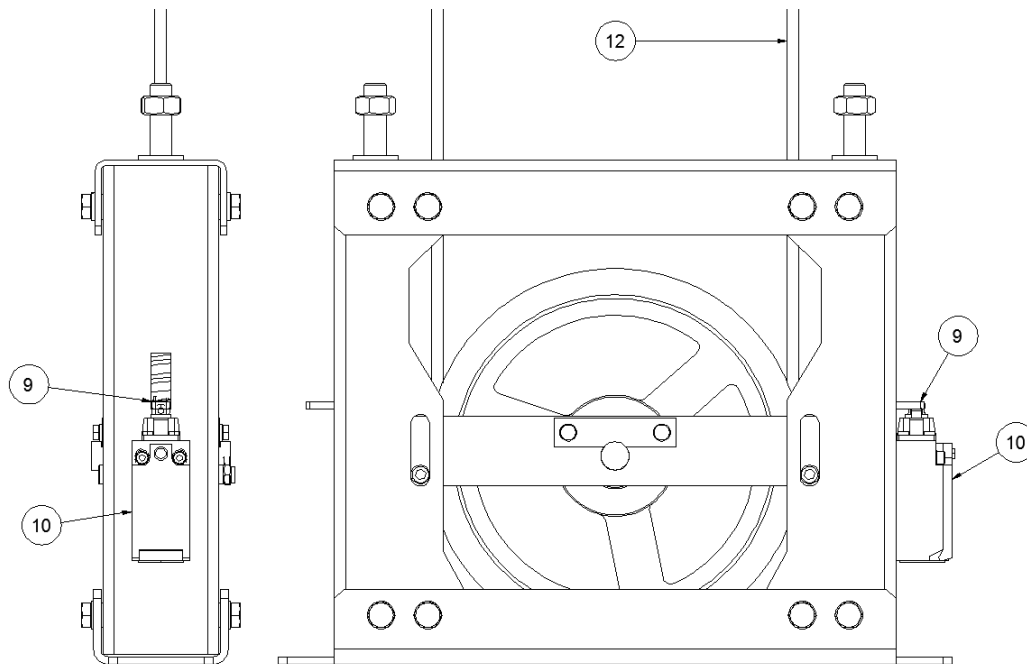

Figure 21: Rope untightening

## 2.6 ROPE RE-TIGHTENING

In case of rope untightening, the rope is to be re-tightened.

In case of not having the rope tensioner option (15) (DIN 1480 M6), tighten the spring-compressing nuts (5) until the de-tensing contact actuator reaches its maximum position. Please remember to tighten the nuts (5) alternatively.

Once the tension in the governor's rope has been released, remove the cable-clips (14) anchoring the rope to the driving bar's governor attachment (13). Then, repeat the process to apply tension onto the rope's free end .

After that, secure the rope via cable-clips . Finally, unthread the nuts (5) as explained in section 2.4.

## 3 TIPS

- Position the Compact tensing pulley in the installation in such a way as it forms a 90° angle with the upper cover (7). .
- Apply enough tension to the governor's rope before securing it with the cable-clip to the driving bar's governor attachment (13). .

## 4 ASSEMBLY'S DRAWINGS

Please find attached the following drawings:

- DYN 66.C001.00
- DYN 66/1.C001.00
- DYN 66/1.C002.00

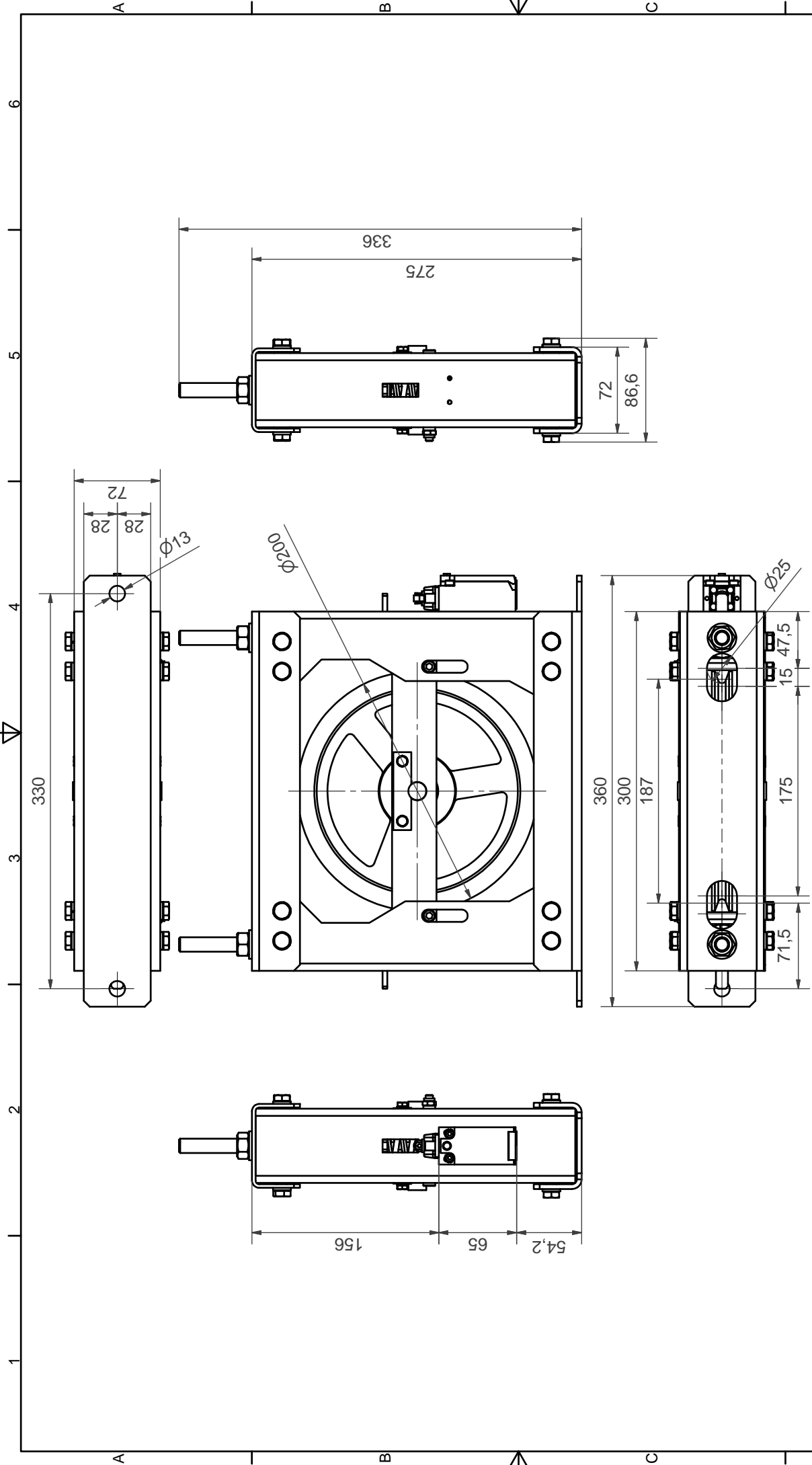

<b>CANTIDAD POR CONJUNTO:</b>		<b>CONJUNTO:</b>	
<b>Material:</b>		<b>POLEA TENSORA COMPACT 200</b>	
<b>Peso terminado:</b>		<b>COMPACT 200 TENSING PULLEY</b>	
<b>Tto. tco:</b>		<b>POULIE DE TENSION COMPACT 200</b>	
<b>Tto. sup:</b>		<b>SPANNROLLE COMPACT 200</b>	
<b>Dibujado</b>	<b>Fecha</b>	<b>Nombre</b>	
<b>Norma</b>			
<b>OBSERVACIONES:</b>		<b>PLANO COD. N°: DYN 66.C001.00</b>	
<b>MEDIDAS SIN TOLERANCIA SEGÚN DIN-7168 GM</b>		<b>Escala:</b>	
<b>Fichero:</b>		<b>Sustituye a:</b>	

**DYNATECH**

**ESCALA:** 1:1

**PLANO COD. N°: DYN 66.C001.00**

**Escala:** 1:1

**Fichero:** Sustituye a:



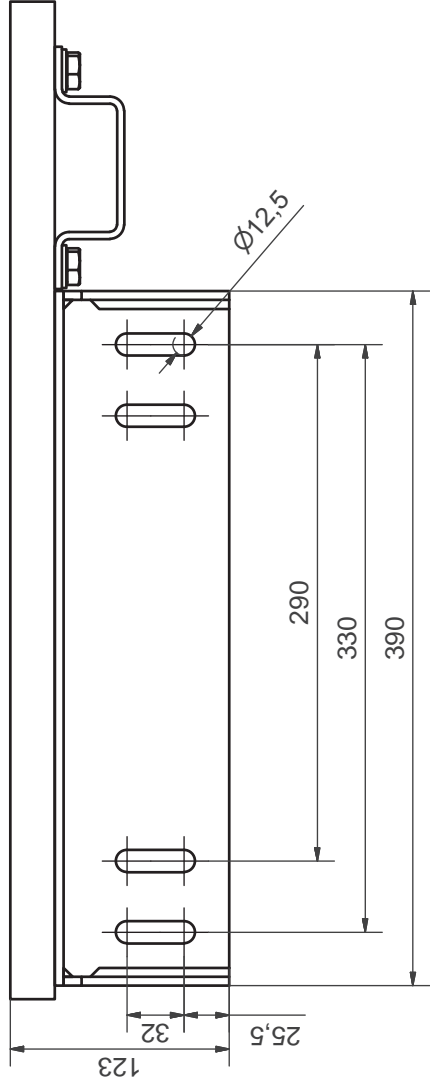
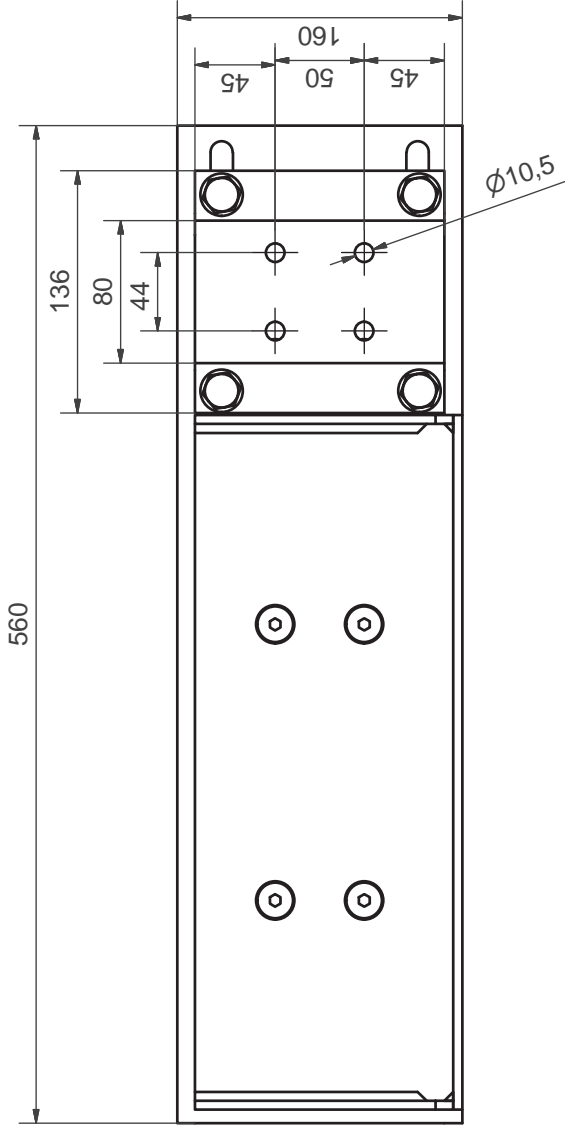

1x Omega unión a guía  
 Omega profile guide rail attachment  
 Omega union au guide  
 Omega-Führungsverbindungssteil

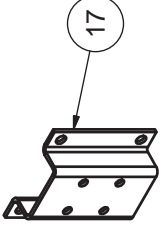

1x Sujeción a guía Compact  
 Compact guide rail attachment  
 Fixation au guide Compact  
 Compact-Führungsbefestigungssteil

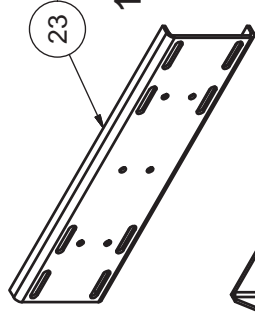

1x Conjunto soporte a guía Compact  
 Compact guide rail Support Unit  
 Ensemble Support au guide Compact  
 Compact-Führungshalterung

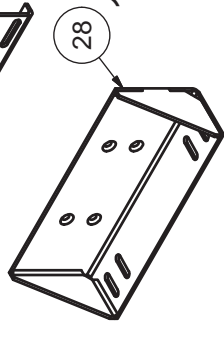

Parts List

ITEM	QTY	DESCRIPTION
18	4	DIN 933 - M10 x 30
19	4	DIN 434 - M10
20	8	DIN 125 - M10
21	8	DIN 127 - M10
22	8	DIN 934 - M10
24	8	DIN 933 - M12 x 30
25	16	DIN 125 - M12
26	8	DIN 127 - M12
27	8	DIN 934 - M12
29	4	DIN 7991 - M10x25

CANTIDAD POR CONJUNTO:

Material:

Peso terminado: 10 Kg

Tto. tco:

Tto. sup:

Dibujado: 21/03/2014

Norma:

OBSERVACIONES:

MEDIDAS SIN TOLERANCIA SEGÚN DIN-7168 GM

Fichero:



CONJUNTO: COMPACT

ADAPTADORES A GUIA COMPACT  
 COMPACT GUIDE RAIL ADAPTER  
 ADAPTEURS À GUIDE COMPACT  
 ADAPTER FÜR DIE COMPACT-FÜHRUNG

ESCALA: PLANO COD. Nº: DYN 66/1.C001.00

Sustituye a:

4

5

6

4

5

6

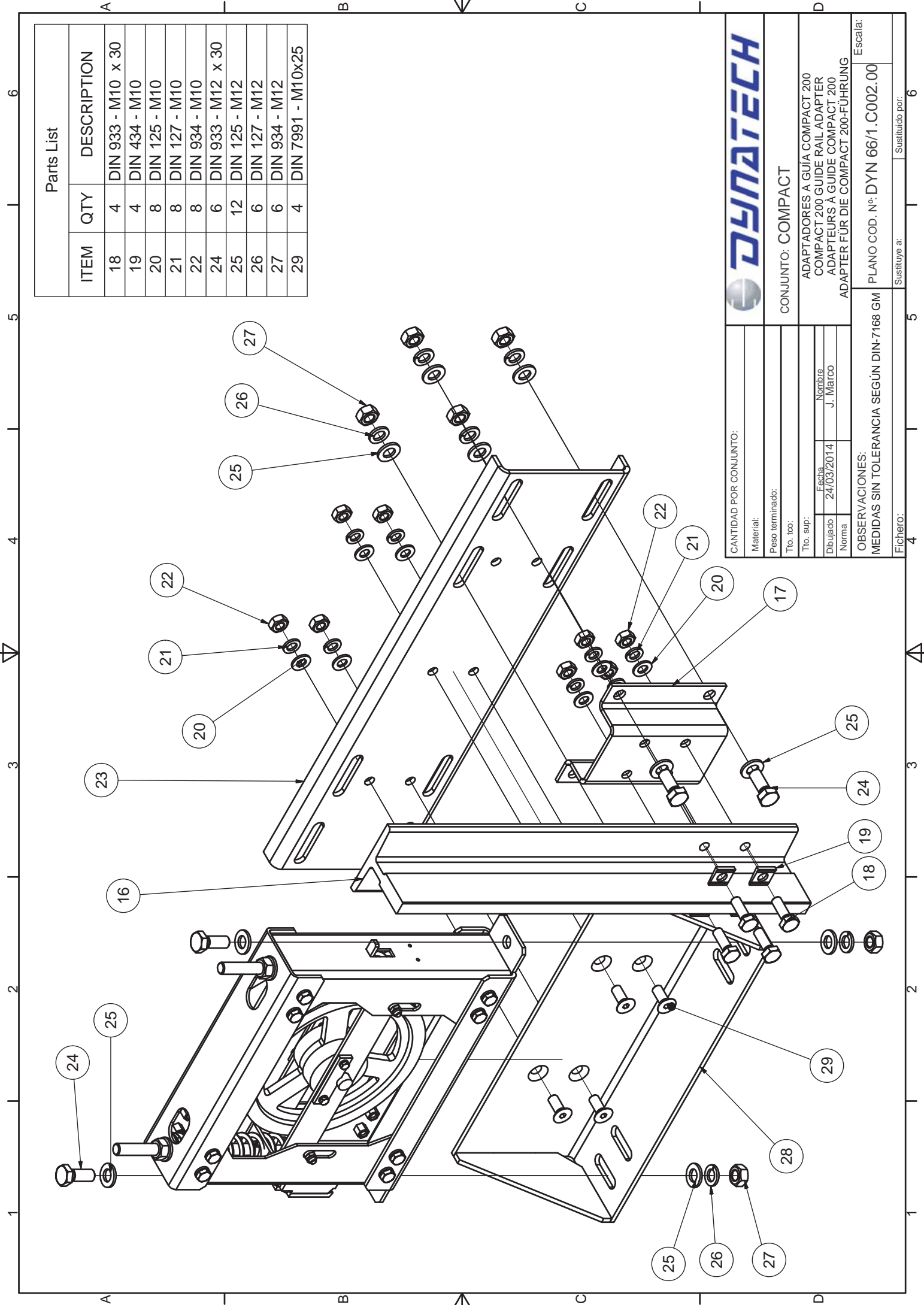

Parts List

ITEM	QTY	DESCRIPTION
18	4	DIN 933 - M10 x 30
19	4	DIN 434 - M10
20	8	DIN 125 - M10
21	8	DIN 127 - M10
22	8	DIN 934 - M10
24	6	DIN 933 - M12 x 30
25	12	DIN 125 - M12
26	6	DIN 127 - M12
27	6	DIN 934 - M12
29	4	DIN 7991 - M10x25

CANTIDAD POR CONJUNTO:	
Material:	
Peso terminado:	
Tto. to:	
Tto. sup:	
Dibujado	Fecha
J. Marco	Nombre
	J. Marco
Norma	

**DYNATECH**

CONJUNTO: COMPACT

ADAPTADORES A GUÍA COMPACT 200  
 COMPACT 200 GUIDE RAIL ADAPTER  
 ADAPTEURS À GUIDE COMPACT 200  
 ADAPTER FÜR DIE COMPACT 200-FÜHRUNG

OBSERVACIONES:  
 MEDIDAS SIN TOLERANCIA SEGÚN DIN-7168 GM

PLANO COD. N°: DYN 66/1.C002.00

Escala: