



LLEC7 load weighing device

Contents

[Safety and usage cautions](#)

[Main features](#)

[System components](#)

[LLEC7 electronic control unit + external sensors](#)

[Optional components](#)

[Management via Fusion APP](#)

[Installation, pairing and use](#)

[Installation](#)

[LLEC7 electronic control unit fixing](#)

[Installation of car bottom sensors](#)

[Installation of ropes sensor](#)

[Installation of car frame sensor](#)

[Wiring Instructions](#)

[General description of the connectors](#)

[Power supply input](#)

[Connection of thresholds](#)

[Connecting sensors for travelling shaft cable compensation](#)

[Connection of the weighing lock function](#)

[Connection of the elevator car bottom sensors](#)

[Connection of ropes' sensor](#)

[Connection of car frame sensor](#)

[Programming](#)

[Programming menu map](#)

[Calibration procedure](#)

[Travelling cable compensation procedure](#)

[Setting thresholds values](#)

[Manually setting of the travelling shaft cable compensation value](#)

[Display of the weight and the voltage of each single sensor](#)

[Datasheet](#)

[Troubleshooting](#)

[Usage tips](#)

[Download](#)





 To check and download all versions of this guide, go at the [following link](#).

Safety and usage cautions

Before installing our products, we recommend you to consult the section about safety and usage cautions at the link below



Main features

- 3 relays thresholds + analog output.
- Automatic compensation of elevator car dynamic load during travel (load locking input).
- It can manage up to 8 individual sensors.
- Adjustable compensation of travelling shaft cable weight.
- Display of the weight and output voltage of each single sensor.
- IPX3 protection through the external cover.
- Device management via Fusion app in local connection.

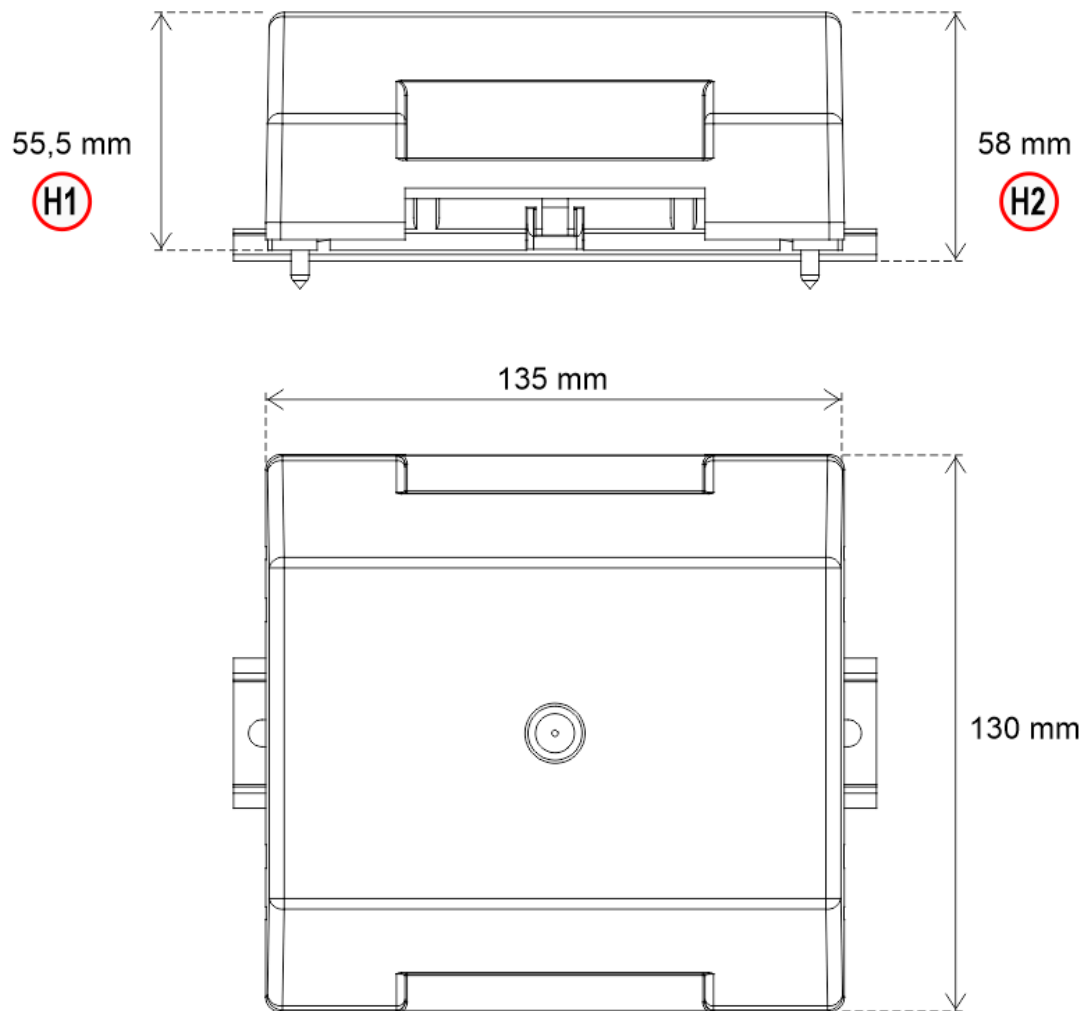

H1 – Fixing with screws

H2 – DIN rail fixing

System components

LLEC7 electronic control unit + external sensors



A

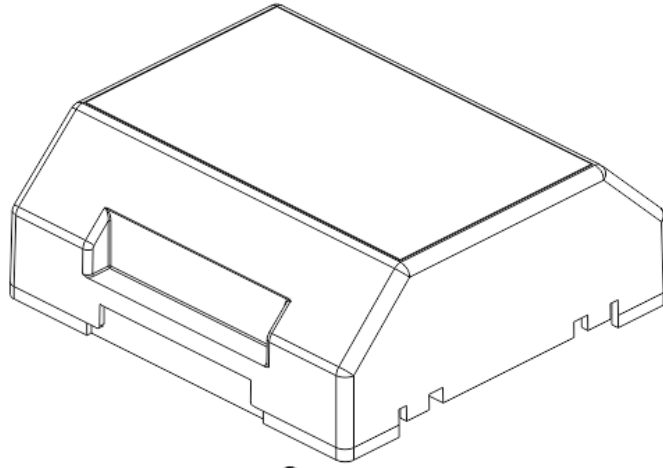

B

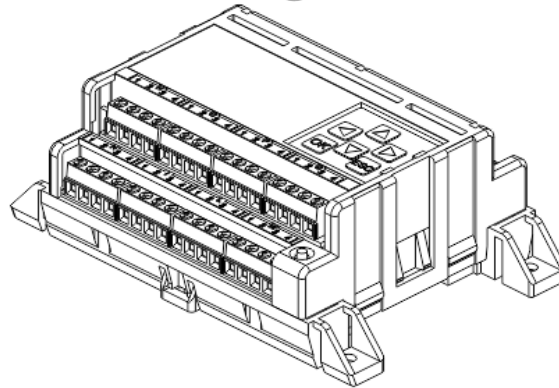

A) – External cover water protection (IPX2)

B) – LLEC7 electronic control unit

C

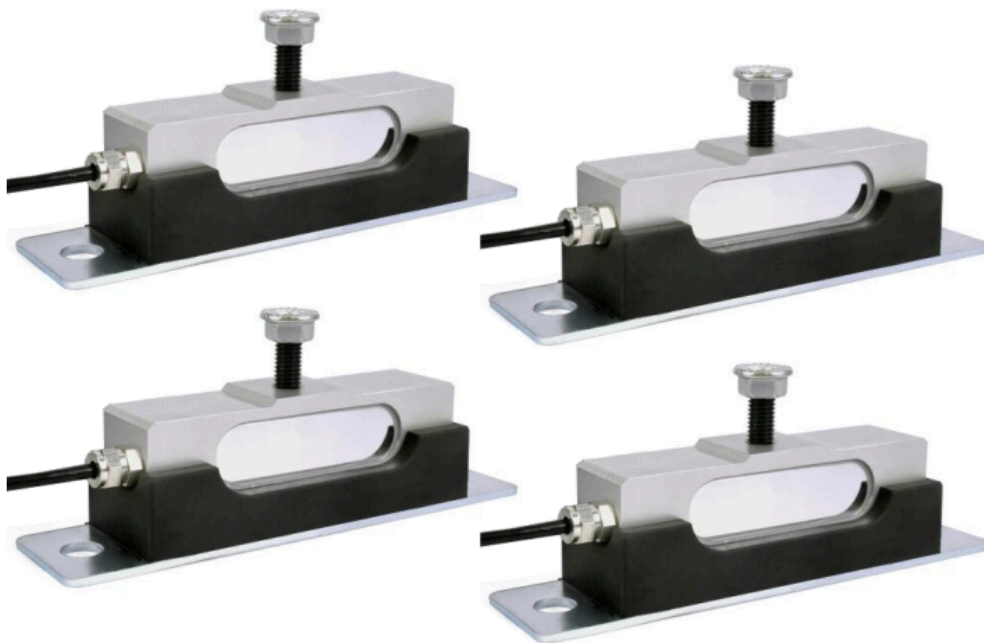

C) – External sensors kit for elevator car bottom (6mt cable)

Optional components



code [AUT.KIT08] – Magnetic sensors (NC)

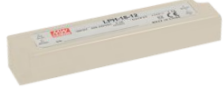

code [EWS.AL212] – Power unit 220V

Management via Fusion APP



The DMG Fusion App, connected via Bluetooth to the LLEC7, allows you to perform all the procedures present on the device.

It is not necessary to log in.

The mobile App interface is an exact copy of the keyboard and LCD display present on the LLEC7, it allows the installer to carry out all operations without interacting directly with the device

Installation, pairing and use

Download and install the Fusion app using the QR code on the side.



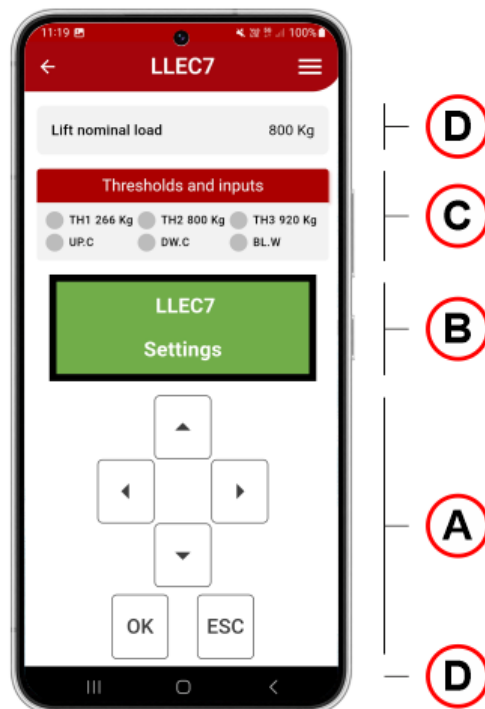
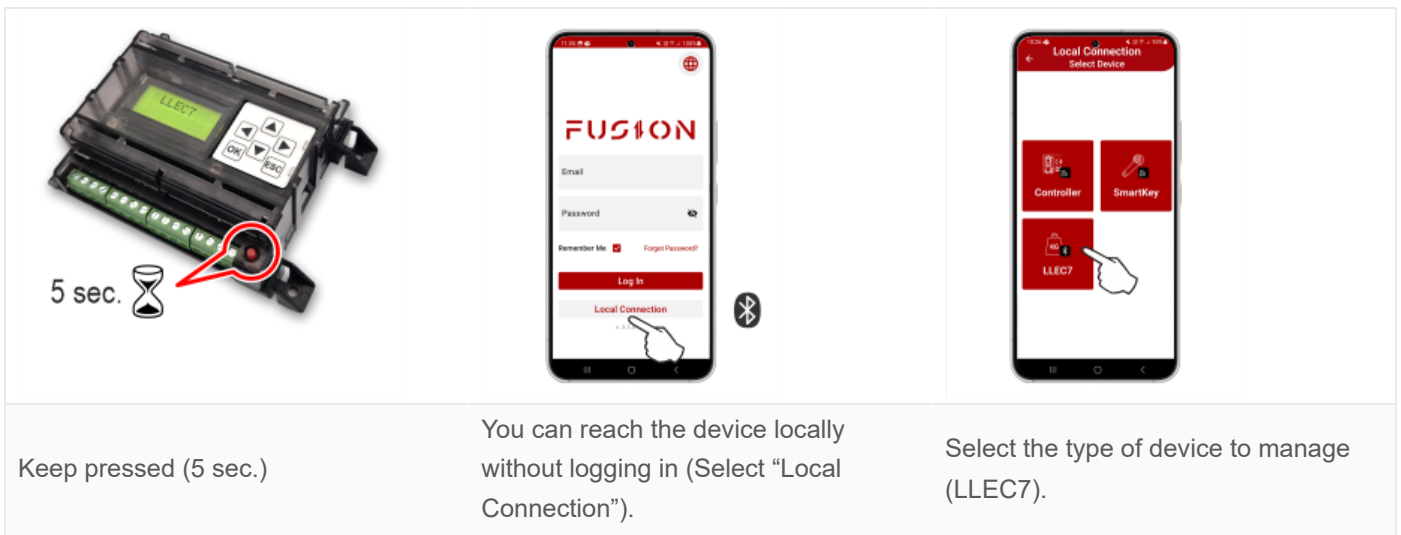

A) Programming keypad

B) LCD display

C) Status and thresholds values / status of the inputs for compensation (UP.C, DW.C) and weight block (BL.W)

D) Also displayed (top and bottom of the screen):

- The values entered during calibration such as Lift load, Number and Type of Sensors, Rope Ratio of the system.
- The HW and SW version of the device.

ⓘ Bluetooth automatically disconnects after 25 minutes of inactivity.

Installation



LLEC7 electronic control unit fixing

– Fixing with screws –

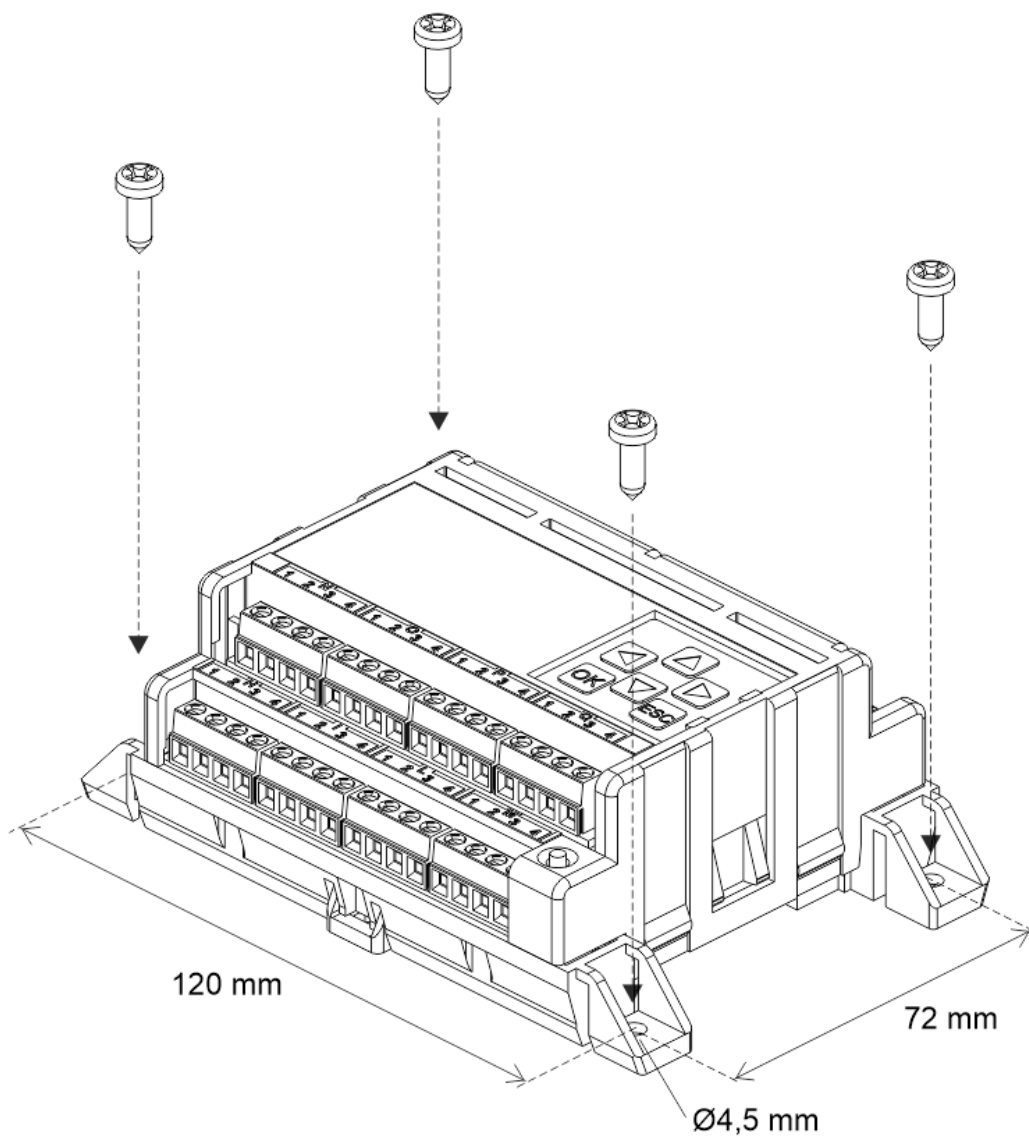

– DIN rail fixing –



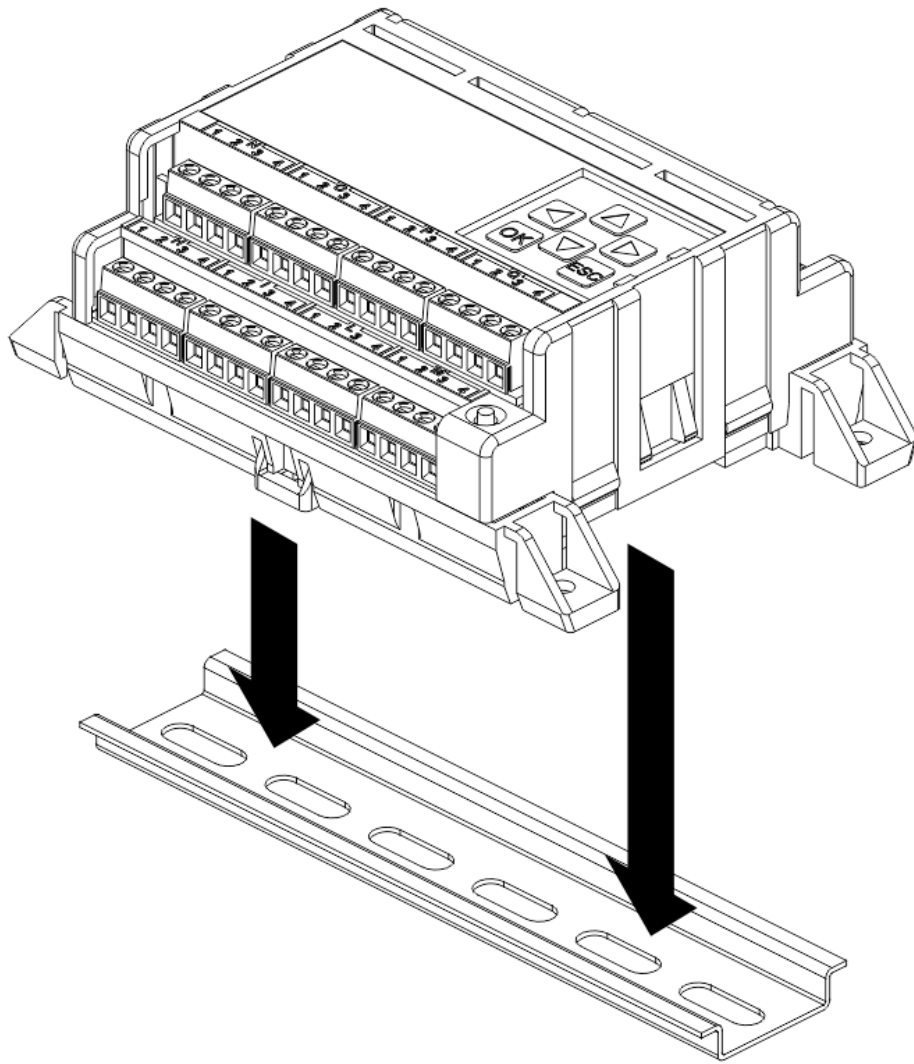

Installation of car bottom sensors



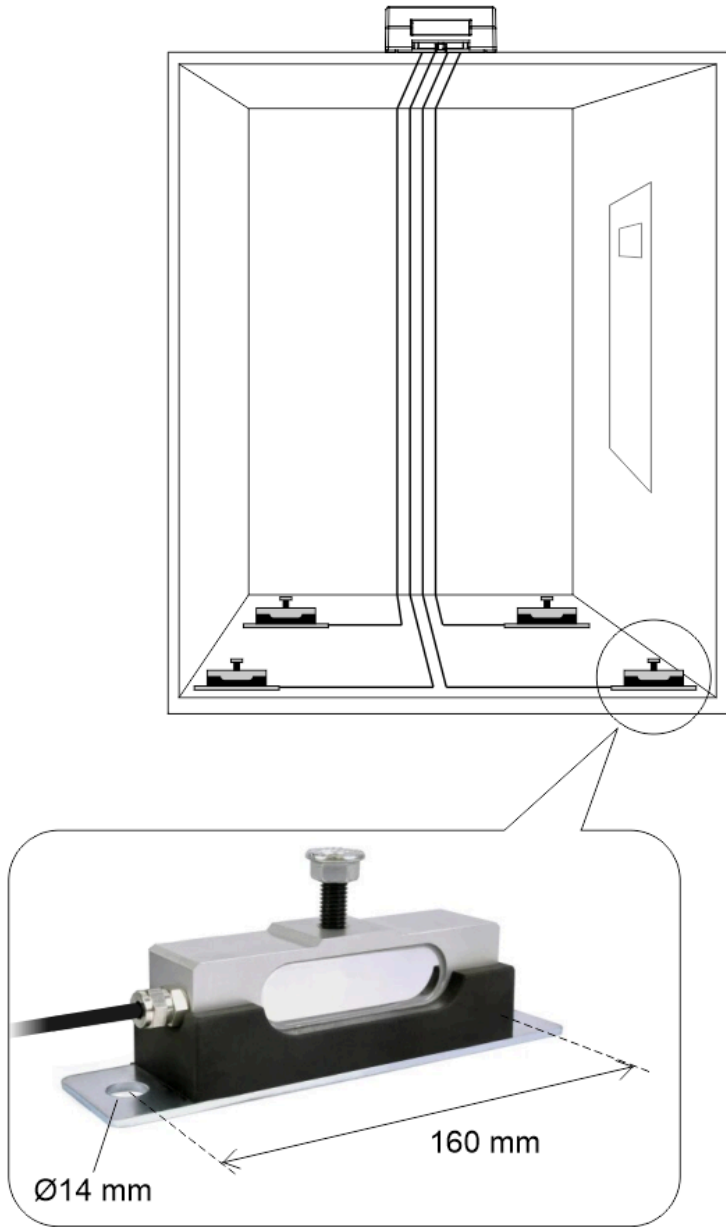

Installation of ropes sensor



MR
(Machine Room)

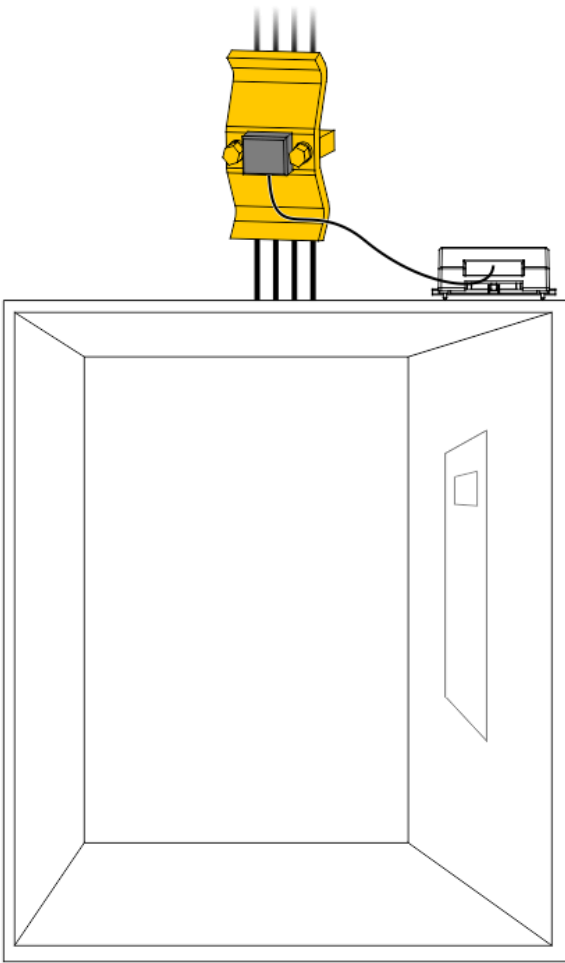

MRL
(Machine Room Less)

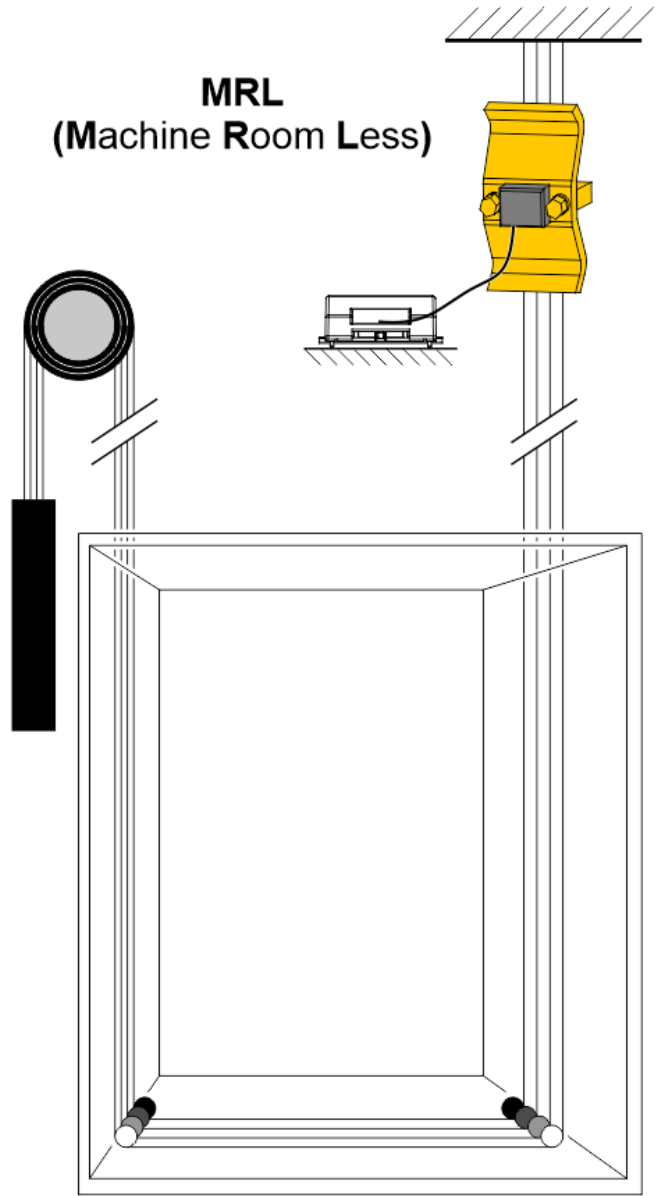

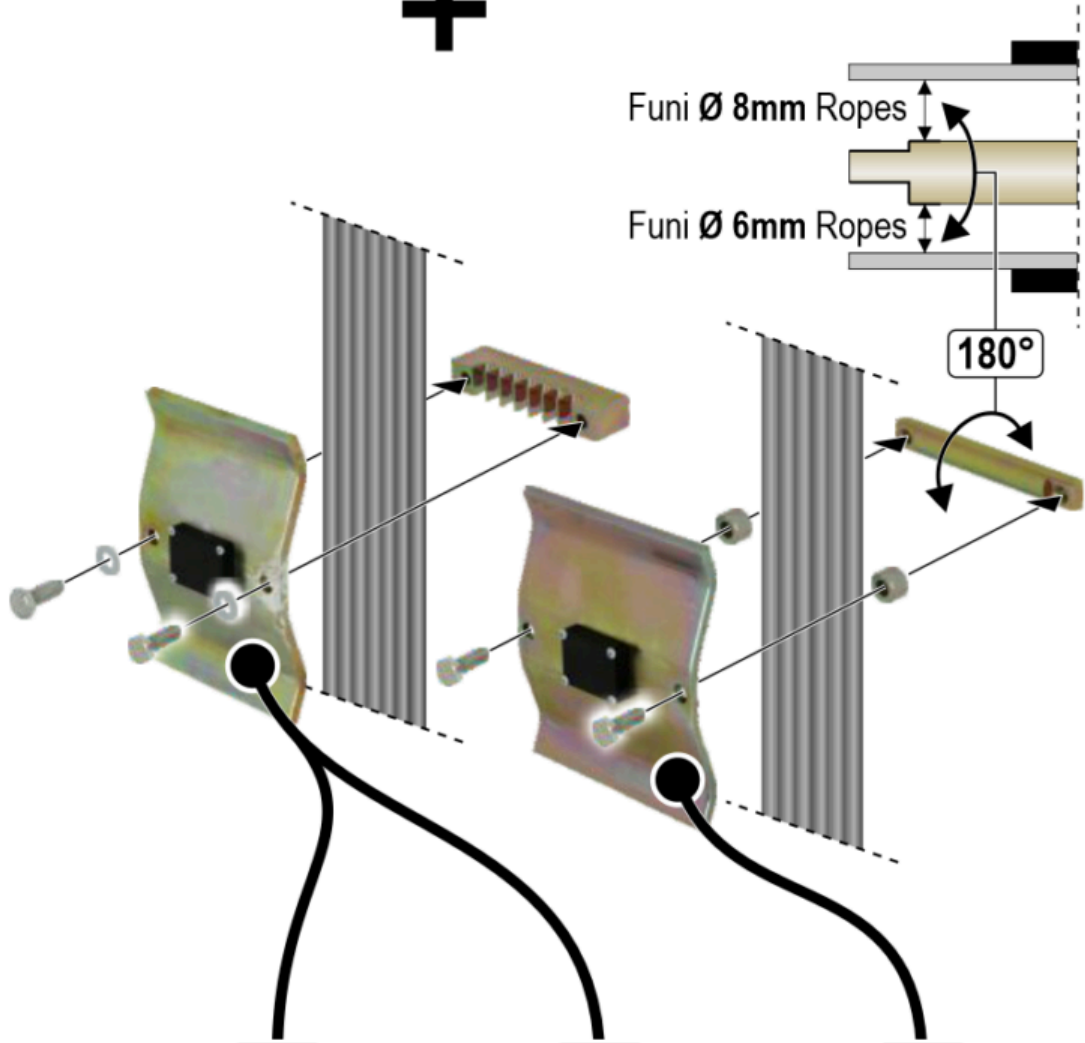

A

Diametro funi <i>Ropes diameter</i>	[EXW.RS6X13] Max 6 funi/ropes	[EXW.RS7X10] Max 7 funi/ropes	[EXW.RS10X8] Max 10 funi/ropes
Fino a/Up to Ø 8 mm			2600 Kg
Fino a/Up to Ø 10 mm		1200 Kg	
Fino a/Up to Ø 12 mm	2200 Kg		
Fino a/Up to Ø 13 mm	2000 Kg		

A) – Maximum load table (Mass structure + lift capacity)
 In case of lift roping 2:1 (sensor on fixed-ending + pulley) maximum load is doubled.

Installation of car frame sensor



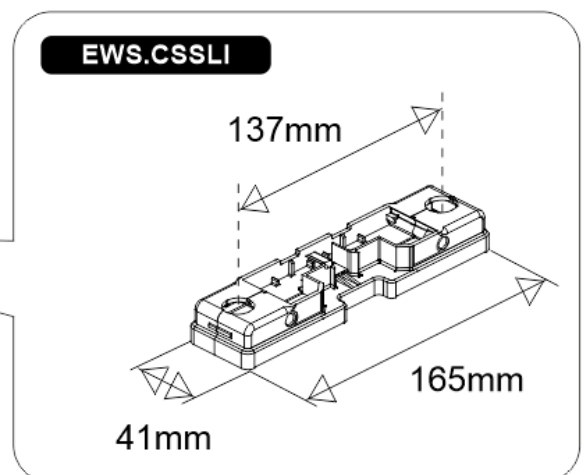
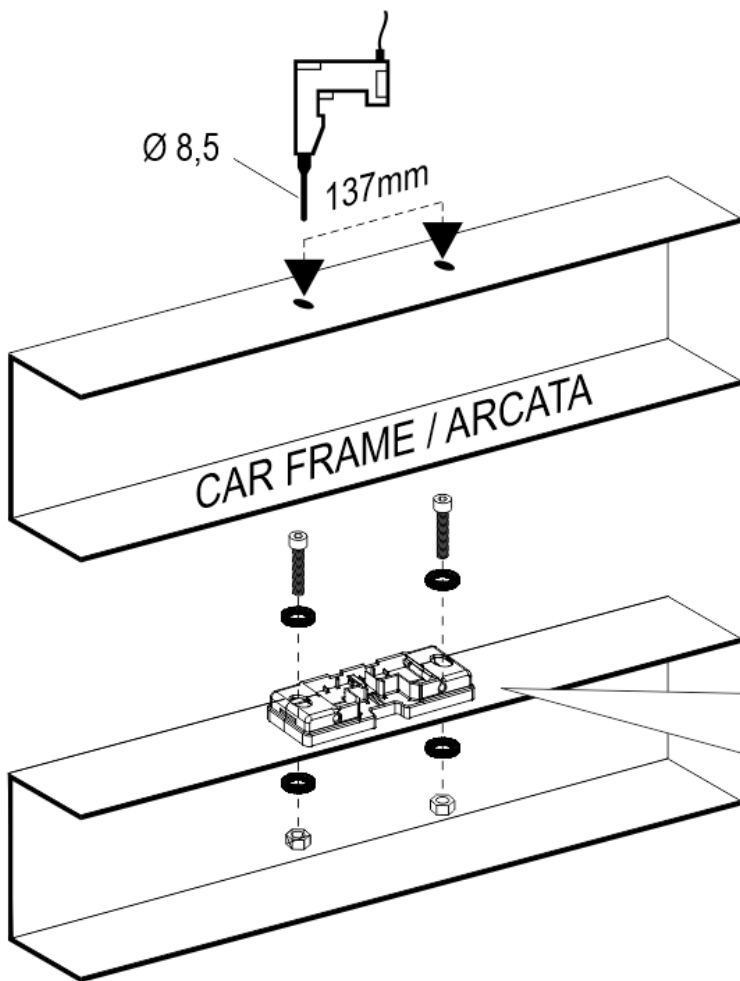
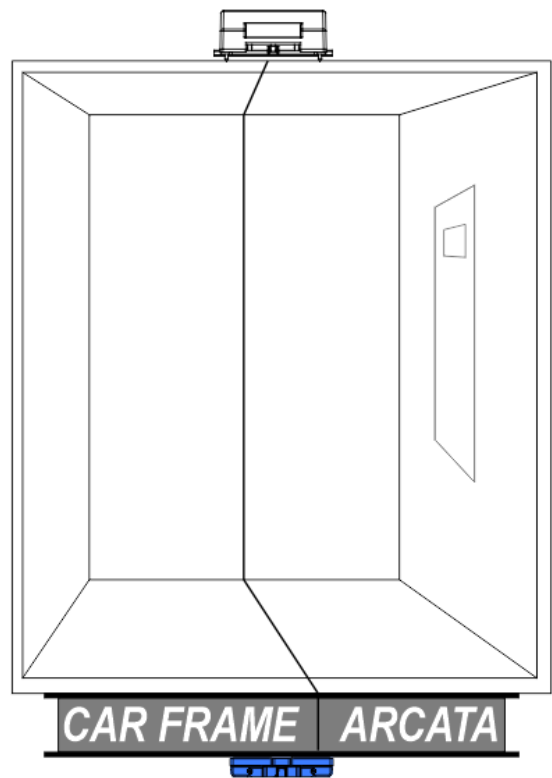
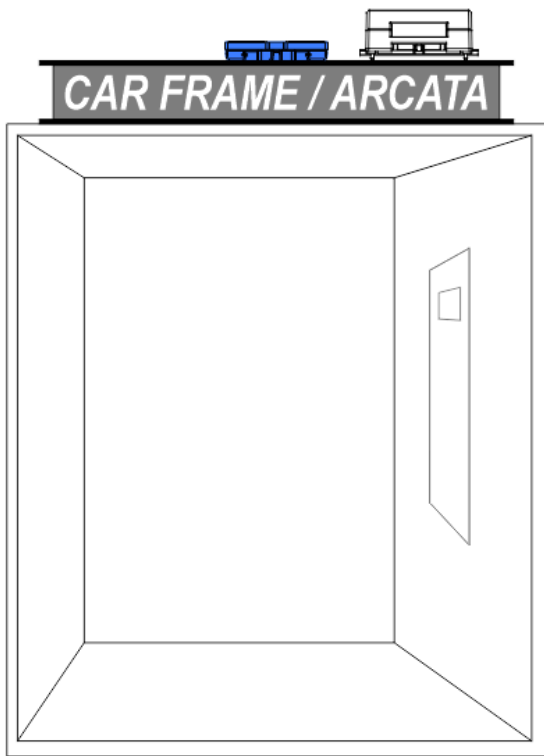

Wiring Instructions



General description of the connectors

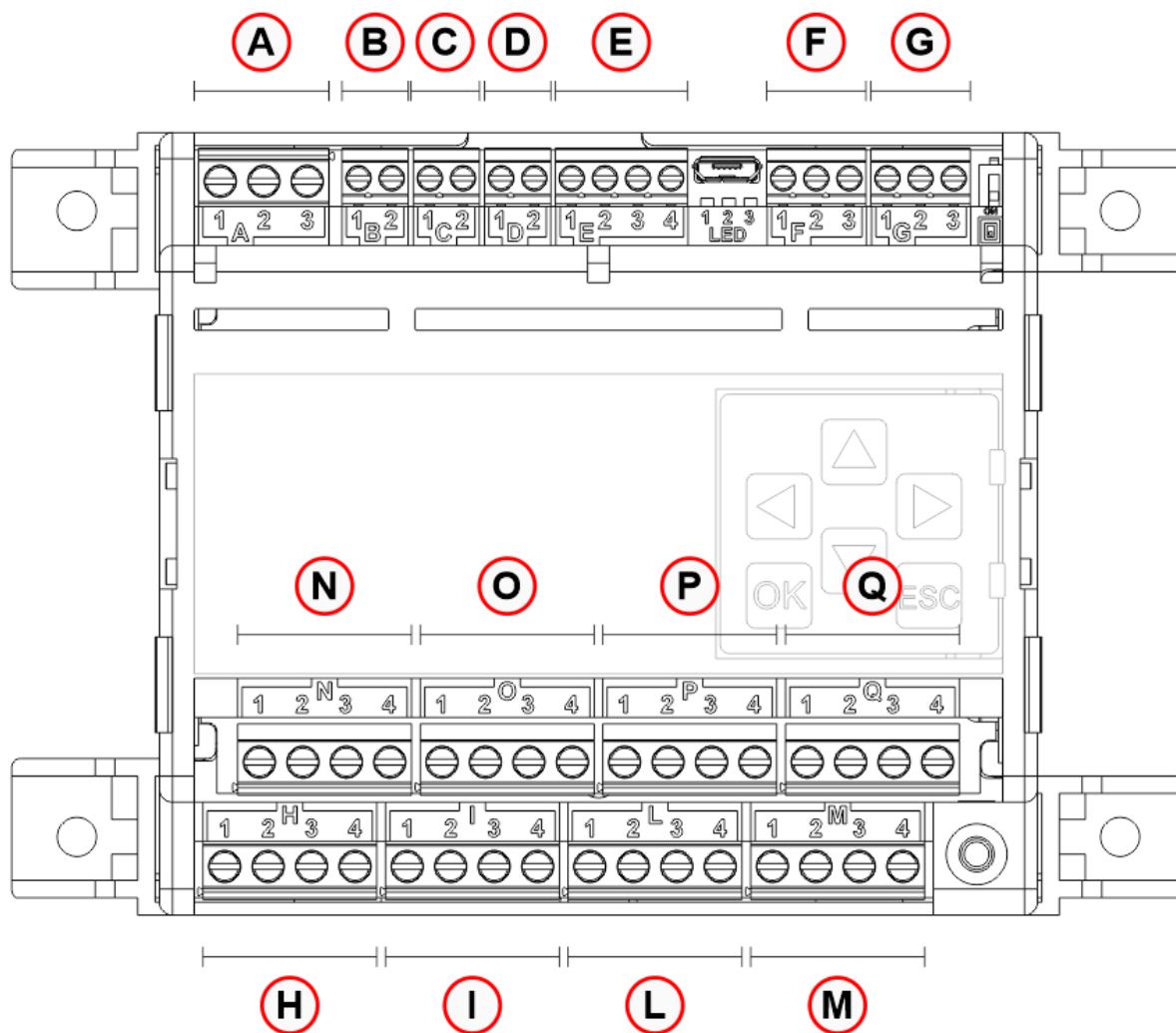

- **A – Power supply input**
 - 1 – Earth
 - 2 – GND
 - 3 – +12/24 Vdc
- **B – Threshold 1 (by default 50% of the lift’s nominal load)**
 - 1 – COM
 - 2 – NO
- **C – Threshold 2 (by default 100% of the lift’s nominal load)**
 - 1 – COM
 - 2 – NO
- **D – Threshold 3 (by default 115% of the lift’s nominal load)**
 - 1 – COM
 - 2 – NO
- **E – Travelling cable compensation input / Block weight input**
 - 1 – GND
 - 2 – UP_COMP
 - 3 – DW_COMP
 - 4 – BLOC_W
- **F – Analog output**
 - 1 – REF



2 – OUT

3 – GND

◦ **G – CAN input** (NOT used)

1 – CAN_L

2 – CAN_SHLD

3 – CAN_H

◦ **H / I / L / M – Sensor input 1 / 2 / 3 / 4**

N / O / P / Q – Sensor input 5 / 6 / 7 / 8

1 – V+ (Excitation +)

2 – S+ (Signal +)

3 – S- (Signal -)

4 – V- (Excitation -)

Power supply input

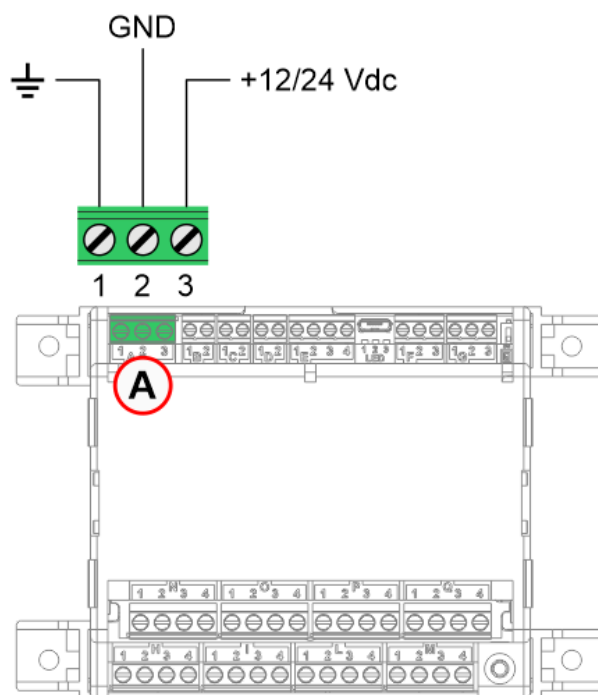

Connection of thresholds



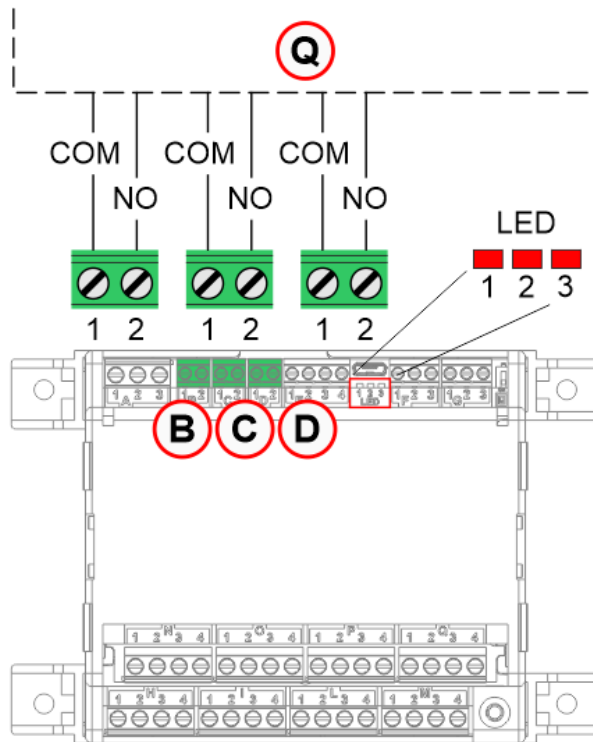

- **B) – Threshold 1 (by default 50% of the lift’s nominal load)**
 - 1 – COM
 - 2 – NO
- **C) – Threshold 2 (by default 100% of the lift’s nominal load)**
 - 1 – COM
 - 2 – NO
- **D) – Threshold 3 (by default 115% of the lift’s nominal load)**
 - 1 – COM
 - 2 – NO
- **Q) – Controller**
- **Threshold LED** – The LED lights up if the threshold is active.

Connecting sensors for travelling shaft cable compensation

In elevators with heavy cable weight, their compensation is an important step. Important to know:

- 1) Lift maximum load.
- 2) travelling cables’ weight per meter.
- 3) Shaft total length.

Before carrying out this procedure, in addition to the main connections, it is necessary to connect the external position sensor [AUT.KIT08].



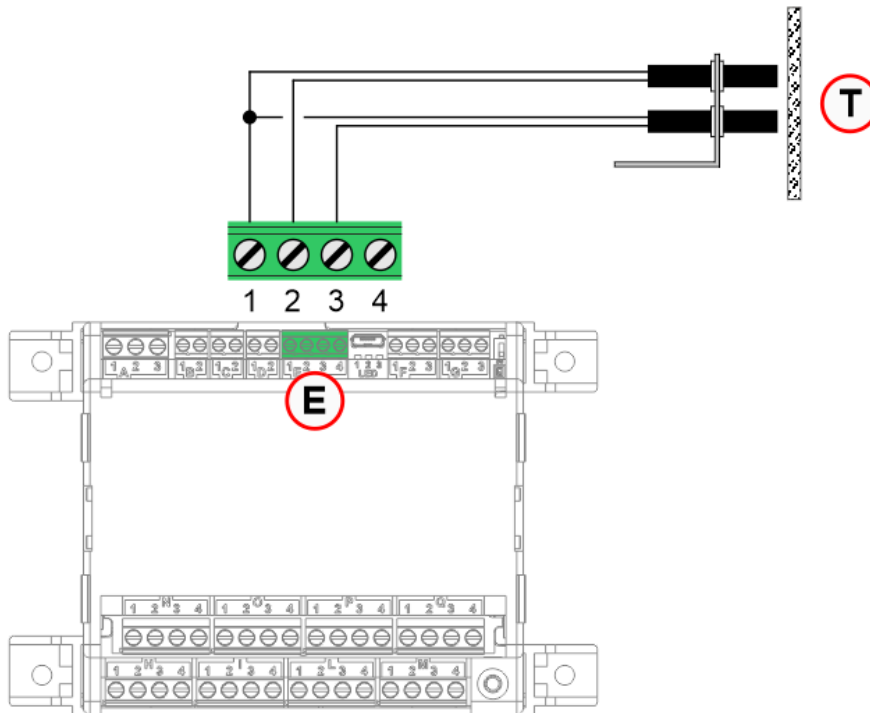

- **E – Travelling cable compensation input**
 - 1 – GND
 - 2 – UP_COMP
 - 3 – DW_COMP
 - 4 – X (See the weighing lock function)
- **T – Position sensors on the top of cabin**

Connection of the weighing lock function

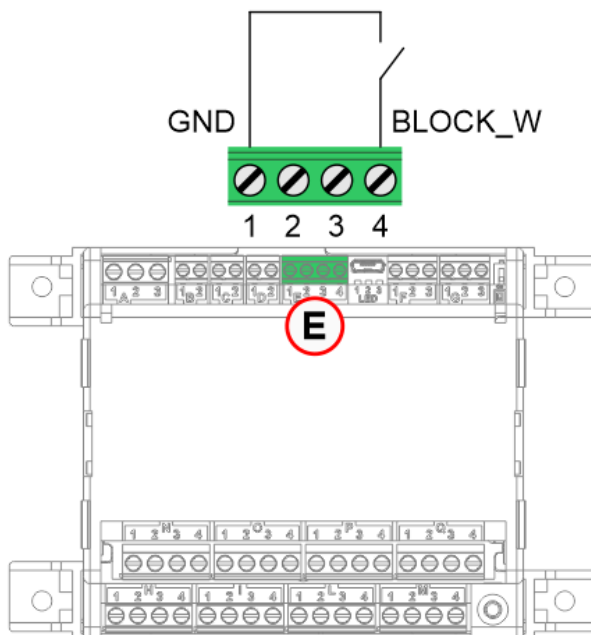

- **E – Block weight input**
 - 1 – GND
 - 2 – X
 - 3 – X
 - 4 – BLOCK_W





The input must not be connected directly to the safety circuit.

Connection of the elevator car bottom sensors

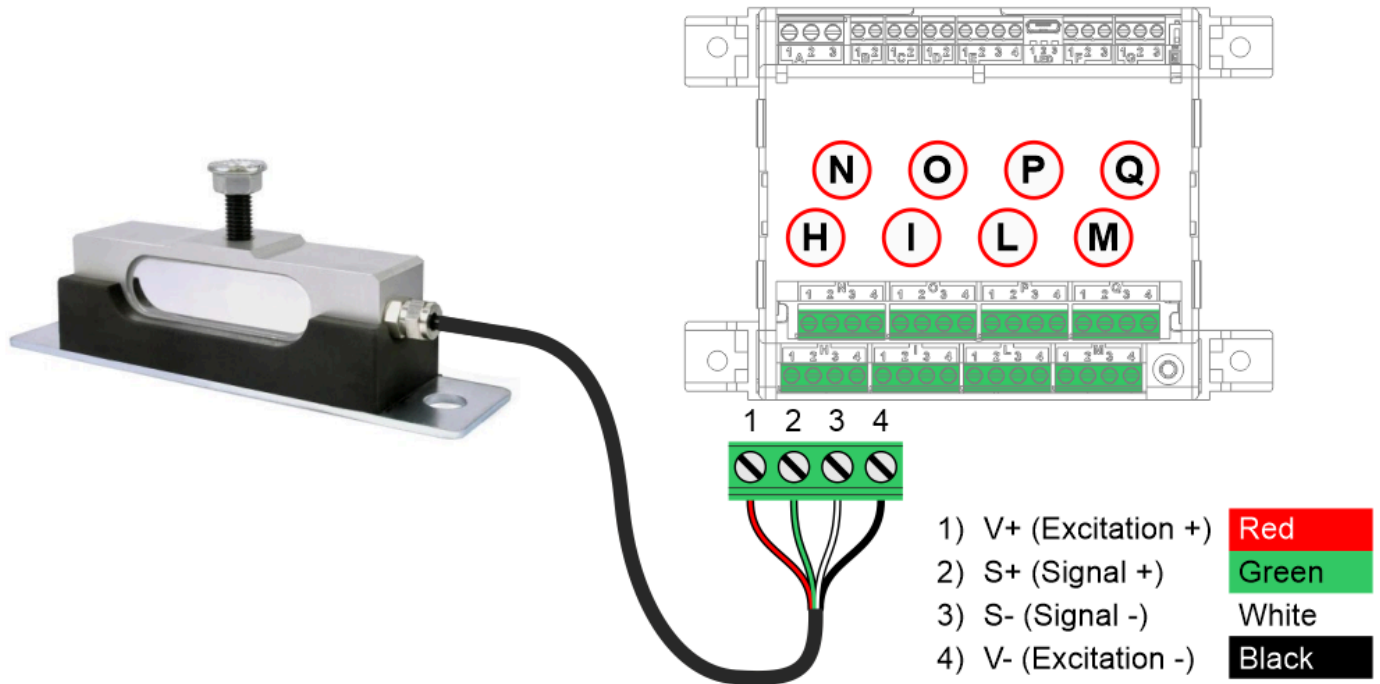

- H / I / L / M – Sensor input 1 / 2 / 3 / 4
- N / O / P / Q – Sensor input 5 / 6 / 7 / 8 (only with optional expansion board)
- 1 – V+ (Excitation +) connected to the red cable
- 2 – S+ (Signal +) connected to the green cable
- 3 – S- (Signal -) connected to the white cable
- 4 – V- (Excitation -) connected to the black cable

Connection of ropes' sensor



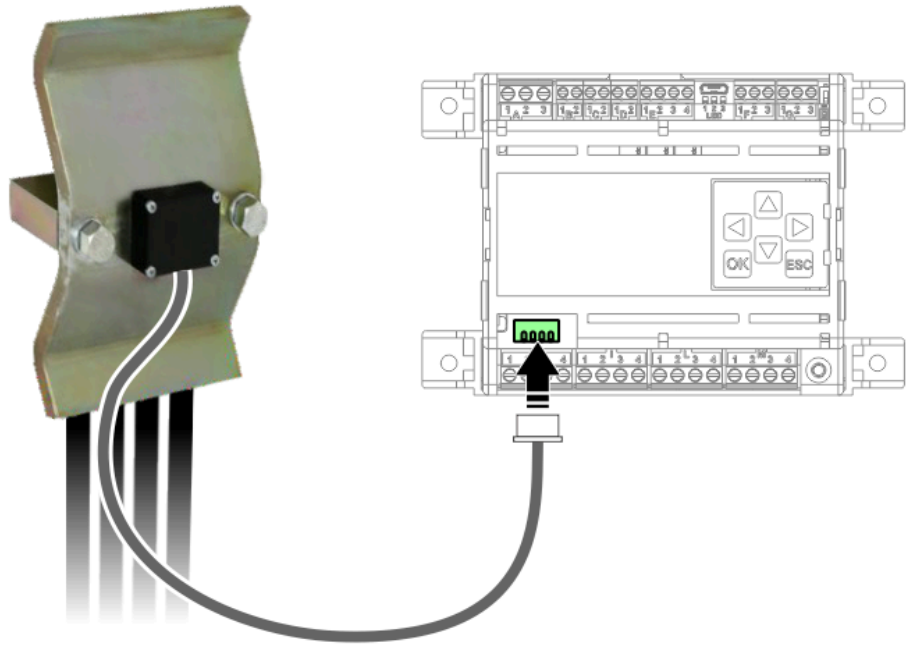
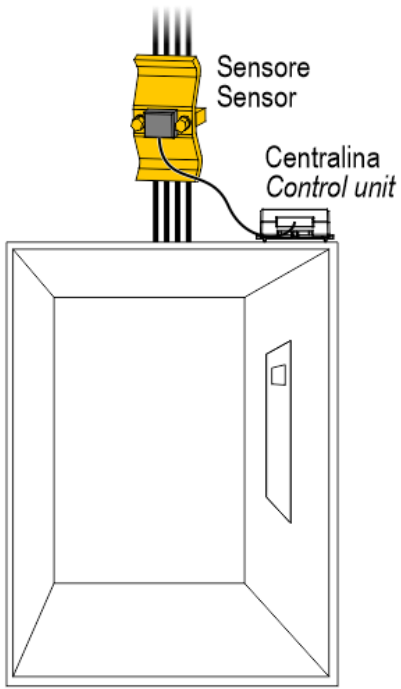

Connection of car frame sensor

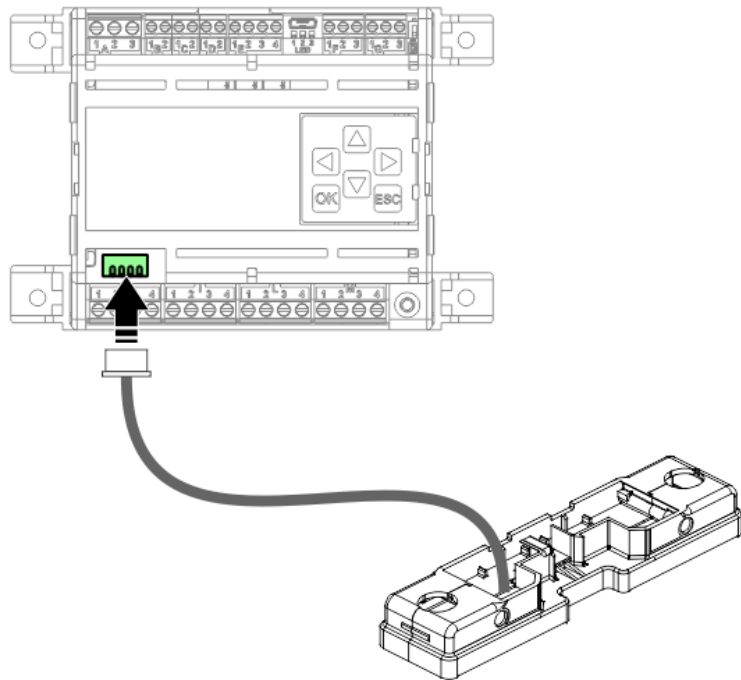
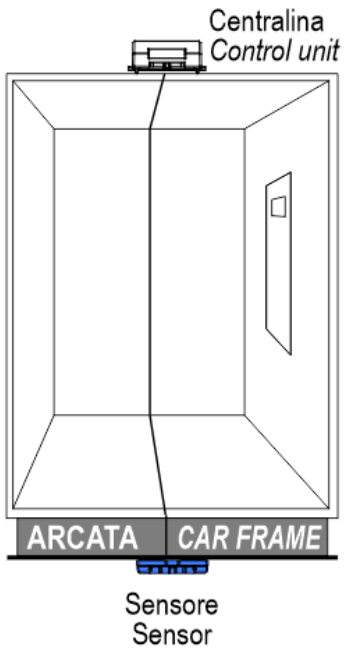

Programming



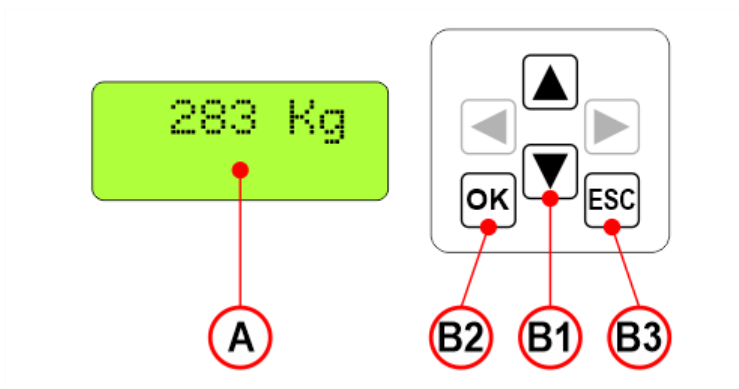

Display after calibration

A) Current weight detected in the elevator car.

Programming keypad

B1) Browse options at current level.

B2) Access the menu and confirm selection.

B3) Exit the current level and return to the previous level.

Programming menu map



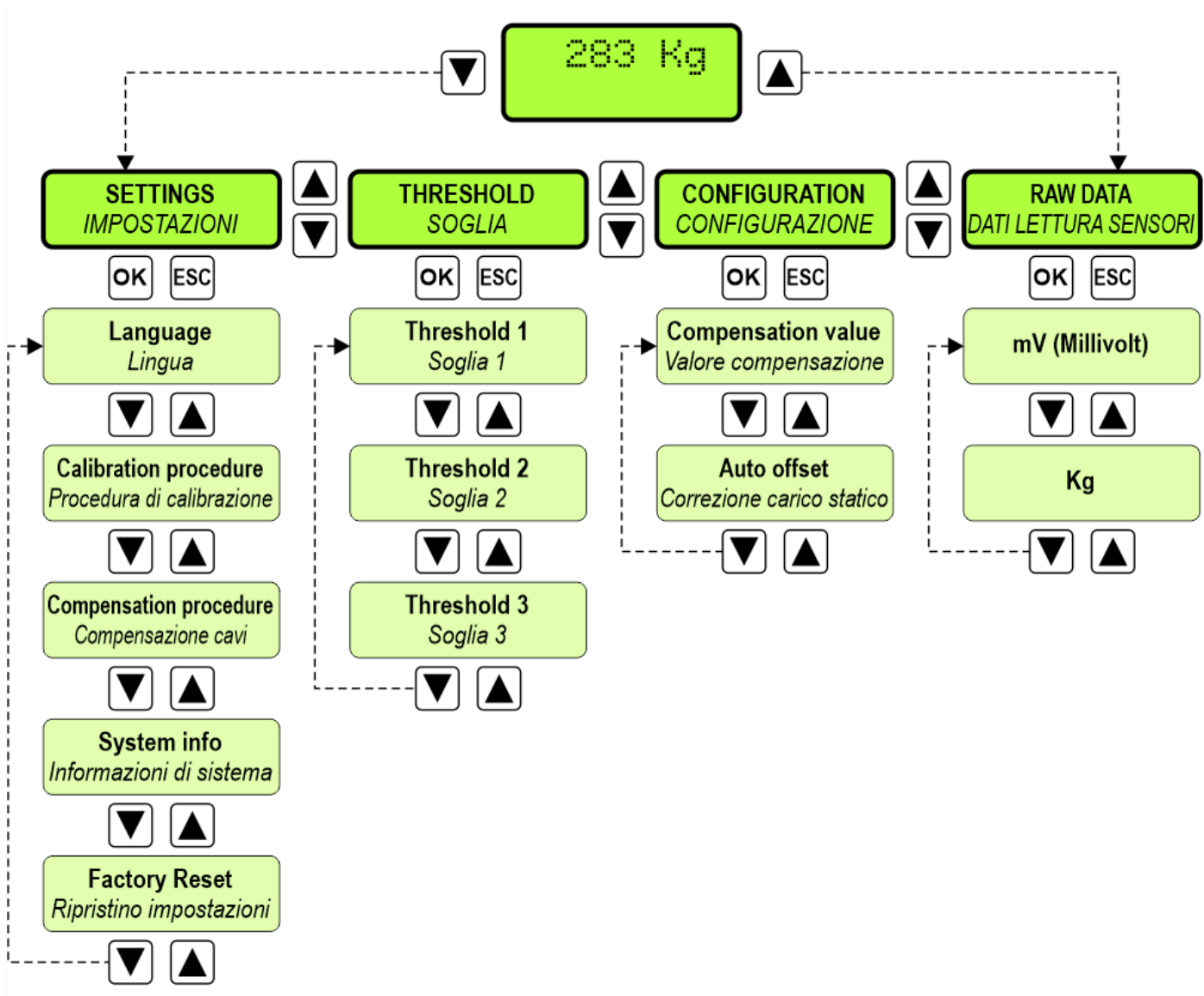

If the calibration procedure has not yet been performed, the main menu screen will display the following message:



Calibration procedure

i Upon startup, the device may require a 5-minute warm-up time.



- i** The system calibration can be performed following 2 different procedures:
- The classic procedure using a reference weight placed in the cabin.
 - Without reference weight in the cabin. This procedure can only be performed with the buffer sensors under the cabin as they are already pre-calibrated in the factory. If you use dummy buffer sensors, use only the procedure with reference weight.

English

Italian

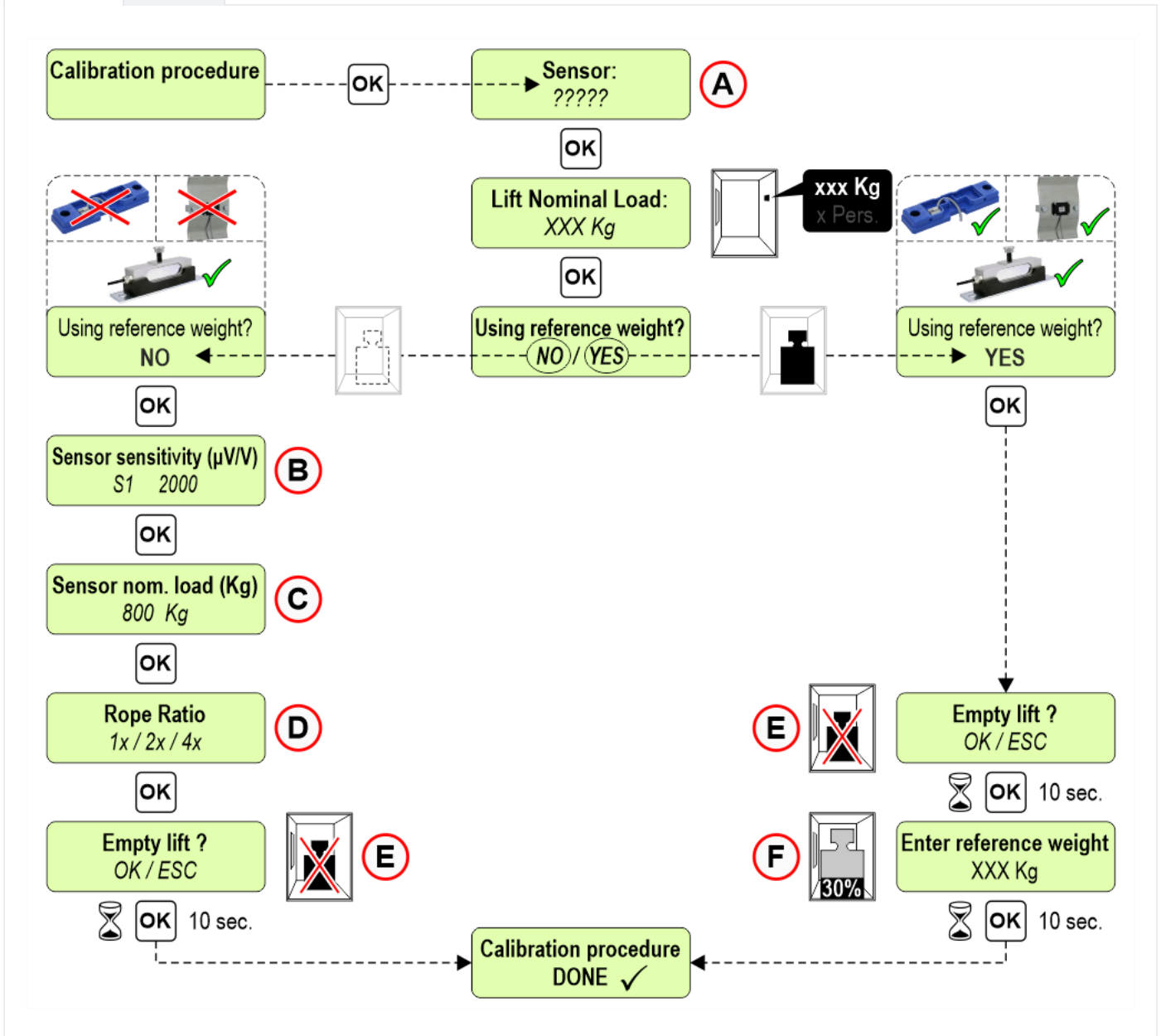

A) For car bottom sensors or single rope sensors, the quantity is also requested.

B) Enter the sensitivity of each sensor (see the label on the sensor).

C) Enter the sensor nominal load.

D) Enter the rope ratio of the system (if it is requested).

E) To carry out the calibration the car must be empty

F) Insert a weight at least 30% of the capacity in the center of the car; the greater the weight entered, the greater the calibration accuracy.

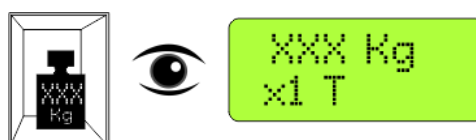

Check the activation of the overload threshold and the correspondence between the real weight in the car and that indicated on the LLEC7 device ($\pm 5\%$).

Travelling cable compensation procedure

Before carrying out this procedure, calibrate the system and connect the AUT.KIT08 magnetic sensors kit (§ [Connecting sensors for travelling shaft cable compensation](#)).

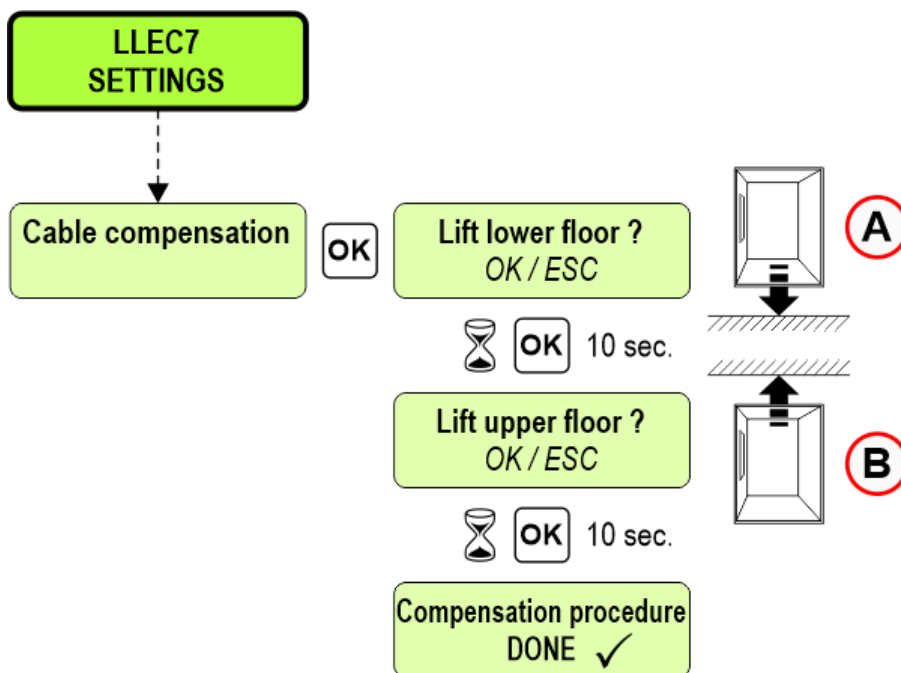

- A) Move the car to the lower floor.
- B) Move the car to the upper floor.

Setting thresholds values

For each threshold it is possible to set the value (Kg) and the type of contact (Normally Open / Normally Closed).



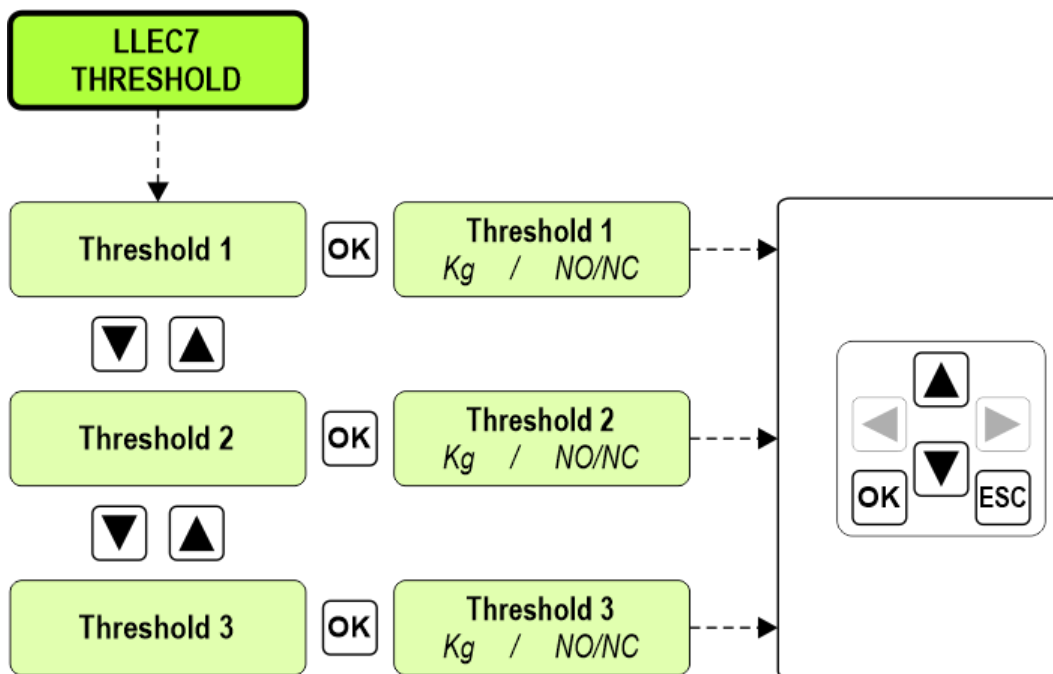

Default values:

- Threshold 1** : 50% of the lift's nominal load / Normally Open
- Threshold 2** : 100% of the lift's nominal load / Normally Open
- Threshold 3** : 115% of the lift's nominal load / Normally Open

ⓘ Reboot the device once the values have changed.

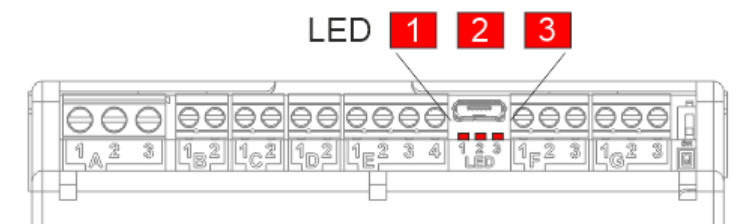

The LED lights up if the threshold is active.

Manually setting of the travelling shaft cable compensation value

It is possible to manually modify the value detected in the travelling cable compensation procedure.

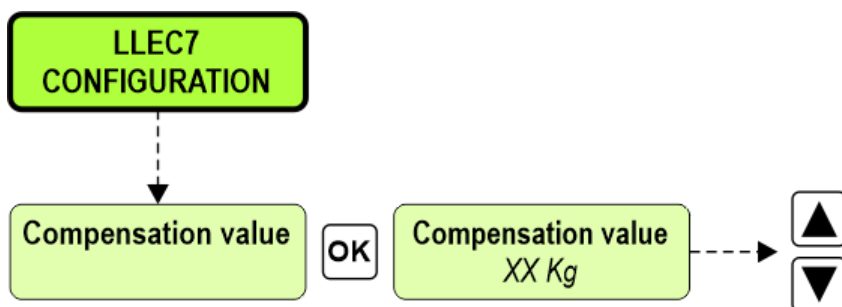

Display of the weight and the voltage of each single sensor



Useful feature for:

- Check the weight distribution inside the cabin
- Check whether there are ropes with different tensions on the system
- Check which sensor is not working

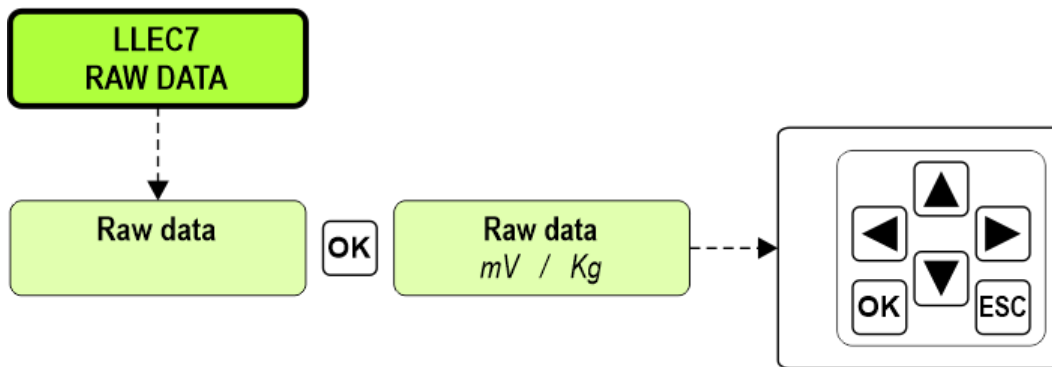

Display the weight (Kg) and the voltage in millivolts (mV) of each single sensor.

Datasheet



LLEC7 electronic control unit	
Voltage	12/24V DC
Max absorption	200 mA
Relays output 1/2/3	1A, 30V DC (Resistive load)
Load locking input	Dry contact
Operating temperature	-10°C ~ +50°C



Car bottom sensor	
Range	800 Kg
Input impedance	1030 ± 10 Ω
Output impedance	1000 ± 2 Ω



Car bottom sensor	
Insulation Impedance	≥ 5000M Ω
Safe Overload	150% F.S
Ultimate Overload	200% F.S
Temperature Effect	± 0,02% F.S/10°C
Operation Temperature	-30°C ~ +70°C
Protection Class	IP67 / IP68
Cable lenght	5 mt

Troubleshooting

Problem	Solution
The device reports an error at the end of the calibration procedure.	Check the correct connection of the sensors.
The device reports an error at the end of the compensation procedure.	Check the correct connection of the magnetic sensors.
The weight detected in the car does not seem correct.	Check all the sensors, viewing the weight and output voltage. (see the "Raw Data" menu).

Usage tips

- On new installations it is advisable to repeat the calibration procedure after some time, since the decrease in friction of the lift could distort the correct functioning of the LLEC7 device.
- It is advisable to never change the length of the sensor cables, as this could influence their factory preset sensitivity.
- Before carrying out the calibration procedure, check that the car is free from any friction with the guides.
- If dummy car bottom sensors are used, the accuracy of the weighing is not guaranteed.

Download

Reference	Version	Link
	1.2 (current version)	Download PDF (English)

Updated on 26 Luglio 2024

