

Door Interlock DL(F)1MO Operating Instructions

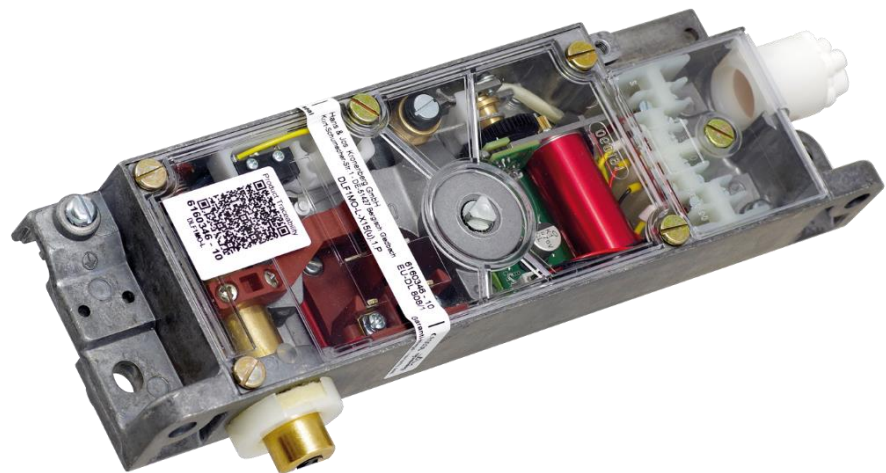

Manufacturer

Hans & Jos. Kronenberg GmbH
D-51427 Bergisch Gladbach

Contact

Hans & Jos. Kronenberg GmbH
Kurt-Schumacher-Straße 1
D-51427 Bergisch Gladbach

T: +49 2204 / 207 -0

E: info@kronenberg-gmbh.de

W: kronenberg-gmbh.de

Document Information

Titel: kro_ba_dl(f)1mo_en.docx, 13.04.2021

Legal Notices

© Hans & Jos. Kronenberg GmbH

All rights reserved.

All photos are property of Hans & Jos. Kronenberg GmbH.

This documentation may not be copied, modified or translated into any other language in whole or in part. Especially when using electronic systems, Hans & Jos. Kronenberg GmbH have to agree to processing, duplication or storage of this documentation.

Contents

1	General information	4
1.1	Intended use.....	4
1.2	Applicable documents.....	4
1.3	EU-Declaration of conformity	4
2	Dimensions.....	5
2.1	Dimensions, parts description	5
3	Function and initial operation	5
3.1	Mode of operation	5
3.2	Initial operation	6
3.3	Settings	6
3.4	Control.....	6
3.5	Closing ability	6
4	Maintenance	6
5	Electrical connection	7
5.1	Connection plan	7
6	Technical information	7
6.1	Operating directions.....	7
6.2	Customary positions.....	7
6.3	Technical data	8
7	Fault correction	8
7.1	Diagnosis at disruption in operation	8

1 General information

In this operating instruction you will find:

- information on the installation, settings and maintenance of the door interlock DL(F)1MO
- assistance in case of disruptions

Read these operating instructions carefully before you start mounting the door interlock DL(F)1MO, as the failure to comply with them might result in severest injuries, environmental damage or damage to the assembly and to the lift installation.

1.1 Intended use

Interlocking device with sliding bolt (and faulty closure device at version DLF1MO), with motor operation for immediate locking of landing doors for lifts.

It must be ensured that the landing door can only be unlocked when the car is in the unlocking area.

Hans & Jos. Kronenberg GmbH do not assume any liability for damages caused by

- improper or incorrect use
- unauthorized repairs or modifications
- use of non-approved spare or accessory parts
- non-observance of this manual

1.2 Applicable documents

- type approval certificate EU-DL 807/1 resp. EU-DL 808/1
- declaration of conformity

1.3 EU-Declaration of conformity

The current version of the declaration of conformity for the door interlock DL(F)1MO is available for download on our homepage kronenberg-gmbh.de.

2 Dimensions

2.1 Dimensions, parts description

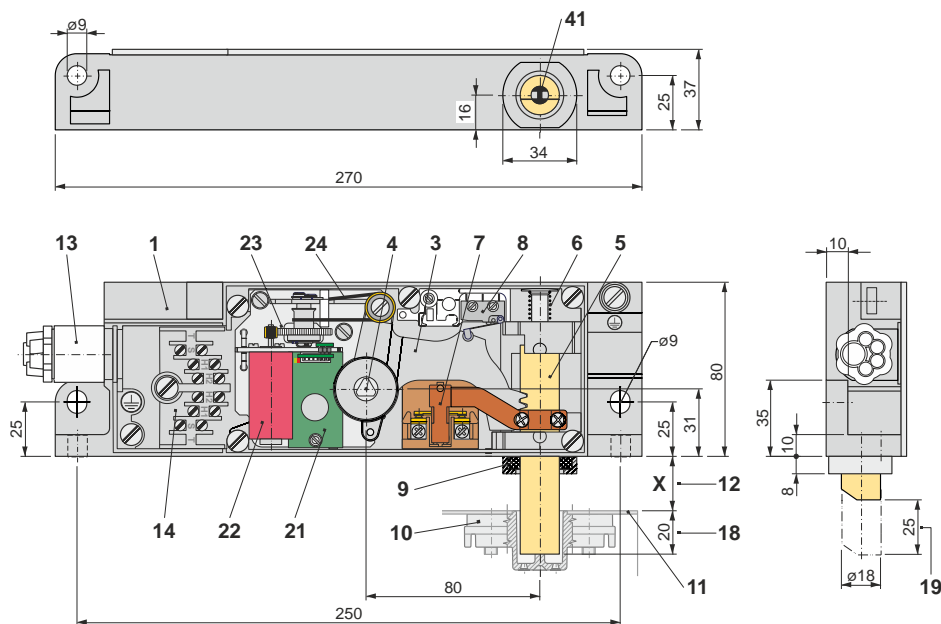

- | | | | |
|----|--|----|---|
| 1 | housing | 21 | motor electronics |
| 3 | tooth lever | 22 | electrical motor |
| 4 | tooth lever axis with triangle | 23 | gear |
| 5 | latch bolt (locking mechanism) | 24 | pull rope |
| 6 | return spring | 41 | faulty closure device (does not apply at DL1MO) |
| 7 | switching for locking mechanism | | |
| 8 | auxiliary switch (as option) | | |
| 9 | oiled felt ring with holder (from $X \geq 10$) | | |
| 10 | latch plate (does not apply at DL1MO) | | |
| 11 | door leaf | | |
| 12 | X-dimension according to customer specification | | |
| 13 | cable entry | | |
| 14 | connecting terminals | | |
| 18 | immersion depth of the latch bolt into the latch plate (nominal dimension) | | |
| 19 | into the latch plate (nominal dimension) | | |

3 Function and initial operation

3.1 Mode of operation

By applying a regulated DC voltage of 24 V to the terminals [22] of the motor electronics the latch bolt [5] is attracted and is held in its end position [LED lights up green].

The switch for locking mechanism [7] [positively driven contact] is thus opened and the safety circuit interrupted. The door is thus unlocked and can be opened.

The bolt can remain tightened as long as requested [100 % duty cycle].

The DC voltage is monitored by the motor electronics [21]. If a drop of the input voltage is detected, the motor current is switched off and the motor brake activated for a short time [red LED flickers]. The latch bolt [5] drops down damped into the latch plate [10], the switch for locking mechanism [7] is closed and the lift car can drive on.

3.2 Initial operation

The following points must be observed during assembly:

- intended use, permissible installation position and environmental conditions
- correct X-dimension [12]
- for the closing ability suitable bevel of the latch bolt
- sufficiently dimensioned fixation
- emergency release [4] accessible (opening with diameter 14 mm)
- suitable latch plate [10] for the DLF1MO with faulty closure device e.g. type BE or BS-V
- sufficiently large opening for the latch bolt [5]
- latch bolt [5] and emergency release [4] + [23] smooth

3.3 Settings

Latch bolt [5] and latch plate [10]:

The distance between the attracted bolt [5] and the latch plate [10] should be 5 mm.

3.4 Control

It must be ensured that the motor electronics are only supplied with voltage when the car is in the corresponding unlocking zone.

The motor can be supplied with voltage as long as requested (100 % duty cycle). The voltage of the motor electronics may be switched off after opening the door in normal operation only when the door has been closed again and the latch bolt can freely plunge into the latch plate or bore hole.

Only then it will be ensured that the engine brake that operates only a few seconds after the voltage has been switched off, makes the bolt drop in a damped way.

3.5 Closing ability

If the latch bolt [5] drops down e.g. due to a power failure at open door, it must still be possible to close the door. Where appropriate please provide a slight bevel at the door edge [11].

4 Maintenance

If the locks are installed correctly, maintenance is generally not required. We recommend an annual inspection at harsh operating conditions:

- tighten fastening screws
- check smooth running of the bolt [5] and the emergency [4] release
- check adjustment of bolt [5] to latch plate [10] [centering, 5 mm distance when attracted]
- remove rough contamination

5 Electrical connection

5.1 Connection plan

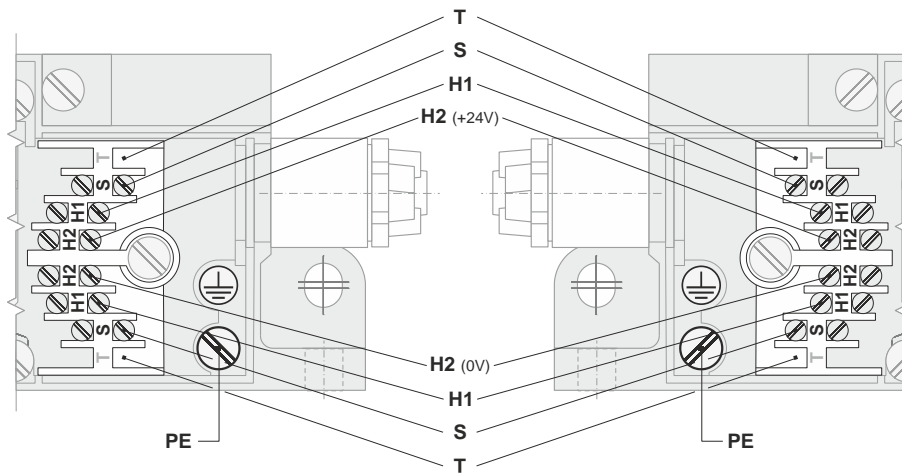

- H1** connection for auxiliary switch
- H2 (+24V)** connection for motor drive
- H2 (0V)** connection for motor drive
- PE** earthing connection
- S** connection switch for locking mechanism
- T** not used

6 Technical information

6.1 Operating directions

-L (latch bolt)

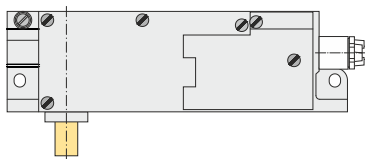

-R (latch bolt)

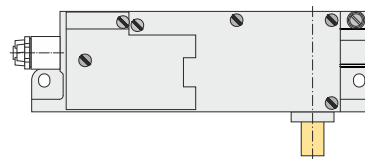

6.2 Customary positions

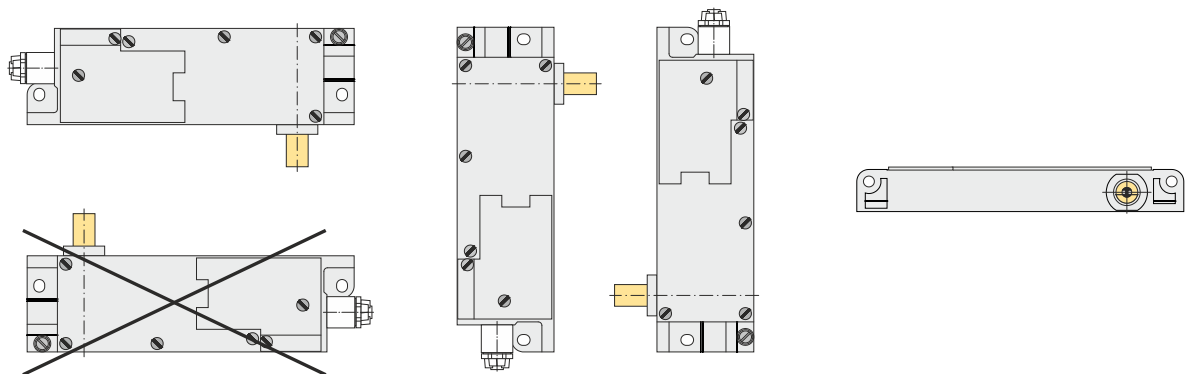

6.3 Technical data

norm	EN 81-20, EN 81-50, EN 60947-5-1
certificates	type approval certificate: EU-DL 808 (DLF1MO) und EU-DL 807 (DL1MO)
switching capacity:	U _i = 250 V I _{th} = 10 A U _{imp} = 4 kV
switch for locking mechanism auxiliary switch .90/01	AC-15: U _e = 230 V I _e = 2 A DC-13: U _e = 200 V I _e = 2 A AC: U _e = 250 V I _e = 6 A EN 61058 DC: U _e = 200 V I _e = 0.25 (0.1) A DC: U _e = 60 V I _e = 1.0 (0.5) A DC: U _e = 24 V I _e = 3.0 (2.0) A
short-circuit capacity	T 10 A F 16 A
contact material	fine silver
motor drive of the latch bolt:	
operating voltage	24 V DC (-10% / +25%) geregelt
pull-in current / time (typical)	0.8 A / < 0,5 s
holding current	0.15 A
connection	by screw terminal max. 2.5 mm ² cable entry PG16 with cable sleeve
level of protection	IP40
ambient air temperature	-10 °C up to +60 °C (special version up to -30 °C)
weight	1000 g to 1200 g (according to version)

7 Fault correction

7.1 Diagnosis at disruption in operation

Disruption	Status LED		Possible cause	Measure
	red	green		
bolt does not attract	off	off	no voltage or reverse polarity	check input voltage and polarity
	on	off	voltage too low	check input voltage, regulated 24 V DC (+/-10%) necessary
	on	on	inappropriate voltage / too low	
attracted bolt sometimes drops down and then retracts			short voltage drop	Determine the cause for the voltage drops and stop it. Check switch, contacts, power supply unit, control, wiring and other consumer-loads.
bolt makes one or several bashing sounds when reaching the end position			Bolt was not dropped down completely, e.g. in faulty closure position. The fixed sequence does not comply, the bolt reaches the final position too soon, the motor continues to rotate and exceeds its breakdown torque.	Normal sequence if the bolt is attracted out of the faulty closure position. If possible ensure that only a completely dropped down bolt is attracted.
bolt makes bashing sounds when attracting, does not reach the end position.	flashes with long interval	on	Bolt or mechanism blocks, motor exceeds its breakdown torque.	Check adjustment and smooth running, remove blockade.